

Force & Torque Measurement Products



CATALOG 25



MARK-10[®]

Force & Torque Measurement Engineered Better



About Mark-10

Mark-10 Corporation is a designer and manufacturer of force and torque measurement products. Since our founding in 1979, our products have proven themselves in numerous applications at companies in the automotive, medical device, plastics, textile, pharmaceutical, packaging, food, and virtually every other industry, worldwide.



Focus On Engineering

Founded in 1979 as an engineering consultancy, and branching out into contract manufacturing in the 1980s, Mark-10 has focused on better engineering and technical expertise from our very beginning. Having developed years of expertise in force measurement, we developed our first force gauge in 1990. Our product line has grown significantly since then, including indicators with remote sensors, manual and motorized test stands, a full range of grips and fixtures, along with software and accessories.



A Culture of Innovation

As an independent, family-run business, we are free to make decisions that best serve our customers' interests. Through frequent collaboration between Engineering, Manufacturing, Marketing, and Sales, we keep a pulse on the market, and address our customers' needs with products which are elegant, easy to use, and cost effective.



Integrated Manufacturing

Within the walls of our fully integrated Copiague, NY facility, a product often starts out as a chat over a cup of coffee. Utilizing the latest in design technologies, CNC machining, and a talented team of technicians and assemblers, product ideas come to life. Technical support and customer service are just down the hallway. With our team under one roof, customer questions and feedback are addressed quickly and accurately.





Industries & Applications



Medical Device & Pharmaceutical

- Needle penetration force
- Tablet crush force
- Suture strength
- Packaging peel force
- Syringe plunger force
- Tubing connector pull-off force
- Dental and bone screw torque
- Stopcock torque
- Catheter torque
- Luer lock torque
- Adhesive strength of bandages
- Latex glove strength
- Mask elastic band strength
- Disinfecting wipes strength



Automotive

- Switch activation force
- Ergonomics / job task analysis
- Rotary dial torque
- Torque tool calibration
- Seat belt retraction force
- Job task analysis
- Fastener torque testing
- Ignition switch torque measurement
- Turn signal stalk activation testing
- Wire terminal crimp pull testing
- Spring testing
- Bearing torque testing
- Coefficient of friction testing
- Windshield wiper arm force



Springs

- Extension spring testing
- Compression spring testing
- Torsion spring testing



Aerospace

- Spring testing
- Wire terminal crimp pull testing
- Force and torque testing of dials and switches
- Passenger control button activation force
- Bearing torque testing
- Cable tension testing
- Tensile strength of materials



Electronics

- Switch force activation
- PCB bend testing
- Wire crimp pull testing
- Component pull-off testing
- Component shear testing
- Peel strength
- Keypad testing
- Connector insertion/withdrawal force



Packaging

- 90° peel testing of adhesive tapes
- T-peel tests of flexible packaging materials
- 180° peel testing
- Opening force testing
- Score bend testing
- Bottle cap torque testing
- Coefficient of friction testing
- Top-load testing of bottles and cartons
- Foil seal pull-off testing
- Sterilized packaging testing



Ergonomics & Job Task Analysis

- Pushing a wheelchair or cart
- Loading and unloading boxes
- Luggage / cargo handling
- Operating heavy machinery
- Muscle strength testing
- Fitness assessment
- Lifting boxes
- Pulling items from racks



Food and Beverage

- Bottle cap torque testing
- Bottle cap pull-off force testing
- Food texture analysis
- Top load testing
- Burst testing
- Crush testing

Table of Contents



Force Gauges 6



Torque Gauges 14



**Plug & Test®
Indicators & Sensors** 18



Wire Crimp Pull Testers 26



Ergonomics Gauges & Kits 28



Manual Test Stands 30



Motorized Force Testers 34
 EasyMESUR® 37
 IntelliMESUR® 48



Torque Testers 60



Software 64



Grips & Attachments 66

Tensile / Pull 67
 Packaging / Peel / Friction 69
 Vise / Parallel Jaw 73
 Wire / Rope / Yarn / Tubing 75
 Compression / Bend / Push 78
 Torque / Force 82
 Basic Attachments & Adapters . 84



Accessories 91

Hardware 91
 Calibration Kits 93
 Power & Communication 94
 Test Frame Accessories 95



Dimensional Drawings 97

Force Gauges 97
 Ergonomics Force Gauges 98
 Torque Gauges 99
 Plug & Test®
 Indicators & Sensors 101
 Wire Crimp Pull Testers 106
 Manual Test Stands 107
 Motorized Force Testers 110
 Torque Testers 112

Configuring a Mark-10 System



F305-IMT

Force Testing Systems

Test frame

Produces the force needed for the test. A test frame eliminates much of the variability inherent in hand-held testing with a force gauge. Motorized and manual models are available.

Force sensor / gauge

Measures and displays the force produced on the test sample. Ranges available from 0.12 to 500 lbf [0.5 N to 2.5 kN]. Accurate up to $\pm 0.1\%$ of full scale.

Control panel

For motorized test frames, choose from IntelliMESUR® or EasyMESUR® integrated motion control and data collection solutions.

Grips and attachments

Choose from a wide range of grips and attachments, many designed for specific tests such as peel testing, wire terminal testing, and more.

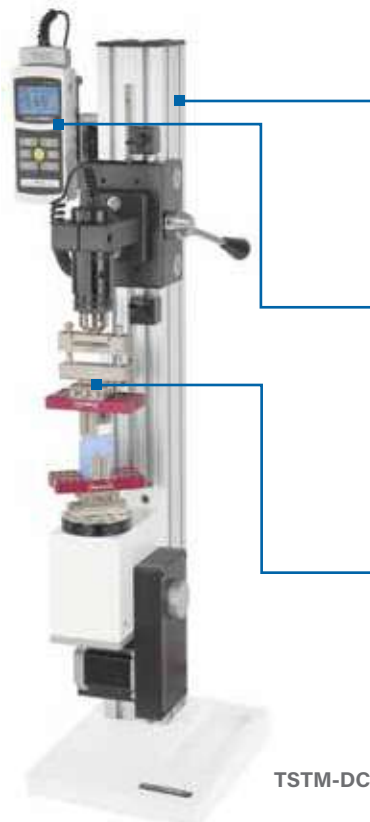

TSTM-DC

Torque Testing Systems

Test stand

Produces the torque needed for the test. A test stand eliminates much of the variability inherent in hand-held testing with a torque gauge. Motorized and manual models are available.

Torque indicator / gauge

Measures and displays the torque being produced on the test sample. Choose a force/torque indicator with Series R50 remote sensor, or the basic all-in-one TT03. Several torque capacities are available. All mount to Mark-10 torque test stands without the need for any extra adapters.

Grips and attachments

Choose from a selection of grips and attachments, designed for such applications as bottle cap torque testing, fastener torque testing, and more.

Force Gauges

Mark-10 digital force gauges can be used in a virtually limitless number of tension and compression testing applications. All force gauges capture the peak force in both tension and compression, and have selectable units of measurement. Capacities are available from 50 gF full scale to 2,000 lbF. Gauges may be handheld or used with a force test stand and gripping fixtures to create a complete testing solution.



www.mark-10.com/force-gauges





Series 7

Professional Digital Force Gauges

Series 7 professional digital force gauges are designed with a number of sophisticated features for the most demanding tension and compression measurement applications, up to 500 lbf (2,500 N). The gauges feature $\pm 0.1\%$ accuracy and a blazingly fast, industry-leading sampling rate of 14,000 Hz, producing reliable results for extremely quick-action tests.

Features:

- **High speed data capture and storage**
Capture and store up to 5,000 continuous data points at a rate of up to 14,000 readings per second. This unique function is ideal for capturing switch activation forces, sharp breaks, and other short-duration applications.
- **Automatic data output / save / zero / I/O pin toggle**
Upon peak force detection, I/O pin toggle can stop a Mark-10 motorized test stand.
- **Programmable footswitch command string**
Up to 3 functions may be specified, along with delays between each function.
- **Custom unit**
A user-defined unit multiplier may be programmed for custom applications.
- **1st / 2nd peak detection**
For tensile testing and other applications.



Series 5

Advanced Digital Force Gauges

Series 5 premium digital force gauges feature a fast sampling rate of 7,000 Hz and $\pm 0.1\%$ accuracy. Additional advanced features such as averaging mode, external trigger mode, password protection, and data memory for 1,000 readings make this flexible gauge series ideal for a wide range of applications. Capacities up to 2,000 lbf [10,000 N].

Features:

- **Communication with external devices**
Full ASCII command set, allowing for communication with a PC, PLC, or other device through USB or RS-232. Mitutoyo and analog outputs also included.
- **Averaging / external trigger modes**
Addresses the need to record the average force over time, useful in applications such as peel testing, while external trigger mode makes switch activation testing simple and accurate.
- **Data memory**
1,000-point data memory with statistics (min, max, mean, standard deviation), and outputs.
- **Password protection**
Passwords may be set for calibration and for individual keys, designed to protect the gauge against unauthorized changes.



Series 5 COF Coefficient of Friction Gauges

The M5-2-COF coefficient of friction (COF) gauge is an integral part of a COF testing system, typically including a motorized test stand and COF fixture. With a capacity of 2 lbf [10 N], the gauge can be used to measure friction for a wide range of materials, ideal for conformance to ASTM D1894 and other relevant standards. Static and kinetic coefficients are displayed on the backlit LCD, and are calculated from a user-programmable sled weight.

Features:

■ Programmable sled weight

The COF is calculated based on the sled weight, adjustable from 100 to 1,000 g, to conform to various standards. A password can be set to protect settings from unauthorized changes.

■ Communication with external devices

Full ASCII command set, allowing for communication with a PC, PLC, or other device through USB or RS-232. Mitutoyo and analog outputs also included.

■ Data memory

1,000-point data memory with statistics (min, max, mean, standard deviation), and outputs.

■ Password protection

Passwords may be set for calibration and for individual keys, designed to protect the gauge against unauthorized changes.



Series 4 Advanced Digital Force Gauges

Series 4 advanced digital force gauges feature a sampling rate of 3,000 Hz and $\pm 0.2\%$ accuracy, producing reliable, accurate results in a wide range of applications. Set point indicators with outputs are ideal for pass/fail testing, while an analog load bar provides graphical representation of applied load. Data memory for 50 readings is also provided, along with data communication capabilities.

Features:

■ Data outputs

USB, RS-232, Mitutoyo, and analog outputs.

■ Data memory

50-point data memory with statistics (min, max, mean, standard deviation), and outputs.

■ Set point indicators with outputs

High, low, and in-range indicators and outputs are activated according to programmed upper and lower set points.

■ Analog load bar

Provides visual representation of applied load, and helps provide feedback for an imminent overload condition.



Series 3

Basic Digital Force Gauges

Series 3 basic digital force gauges feature a sampling rate of 2,000 Hz and $\pm 0.3\%$ accuracy, ideal for numerous applications in virtually every industry. Set point indicators are useful for visual pass/fail testing, while an analog load bar provides graphical representation of applied load. Ultra-compact, reversible housing allows for flexibility in many mounting configurations with space constraints.

Features:

- **USB data output**
Continuous or individual readings may be output to a PC through included USB output.
- **Set point indicators**
High, low, and in-range indicators are displayed according to programmed upper and lower set points.
- **Analog load bar**
Provides visual representation of applied load, and helps provide feedback for an imminent overload condition.
- **Ultra-compact design**
Allows for flexibility in many mounting configurations. Reversible housing allows for hand-held use or test stand mounting.



Series 2

Economical Digital Force Gauges



Series 2 digital force gauges are designed for basic tension and compression force testing applications up to 500 lbF (2,500 N). Peak tension and compression readings are reliably captured via the gauges' $\pm 0.5\%$ accuracy and 500 Hz sampling rate. A backlit graphic LCD displays the current, peak tension, or peak compression reading. Features an ultra-compact, reversible housing.

Features:

- **Peak capture**
For compression and tension measurements.
- **USB data output**
Continuous or individual readings may be output to a PC through included USB output.
- **Battery or AC powered**
Powered by a rechargeable battery or AC adapter.
- **Ultra-compact design**
Allows for flexibility in many mounting configurations. Reversible housing allows for hand-held use or test stand mounting.





Specifications

	 Series 7 Professional	 Series 5 Advanced	 Series 4 Performance
Accuracy (% of full scale)	±0.1%		±0.2%
Sampling rate	14,000 Hz	7,000 Hz	3,000 Hz
Resolution	1/5,000		1/2,000
Outputs	USB, RS-232, Mitutoyo, Analog		
RS-232	Configurable up to 230,400 baud	Configurable up to 115,200 baud	
USB	Configurable up to 230,400 baud	Configurable up to 115,200 baud	
Mitutoyo (Digimatic)	Serial BCD suitable for all Mitutoyo SPC-compatible devices		
Analog	±1 VDC, ±2% FS at capacity. Positive for compression, negative for tension		
General purpose I/O	Three open drain outputs, one input		
Set point	Three open drain lines		
MESUR® Lite software included	Yes		
Data output functionality	Automatic output or by pressing DATA button, or requesting from a PC or other device		By pressing DATA button, or requesting from a PC or other device (currently displayed reading only)
ASCII command set for external control	Full command set		"?" only (request current reading)
Interface w/MESUR®gauge and MESUR® Lite	Full communication		Single point or continuous data output only
Interface w/ESM303 / 750 / 1500 test stands	Full communication, including PC control		Limited to force data, overload protection, and force set points
Data memory (readings, with output)	5,000	1,000	50
Data memory deletion	Any individual data point, or clear all		
Statistic calculations and output to PC	Max, min, mean, std. dev., number of readings, with output		
Break detection	Yes*	No	
1st / 2nd peak detection	Yes*	No	
Programmable footswitch command string	Yes	No	
Averaging mode	Yes*	Yes	No
External trigger mode	Yes**	Yes	No
Analog load bar graph shown on display	Yes		
Set points (for pass / fail indication)	Yes with high / low indicators, markers on analog bar graph, and outputs		
Password protection	Yes, for calibration and individual keys		No
Peak readings always displayed	Yes		
Programmable audible tones	Yes		
Calibration procedure	Configurable number of data points (up to 10 in each direction)		
Overload outputs	Dedicated pins for tension and compression		
Battery life	Rechargeable. Backlight on: up to 7 hours of continuous use / Backlight off: up to 24 hours of continuous use		
Units of measurement	lbF, ozF, gF, kgF, N, kN, mN (depending on model)		
Safe overload	150% of full scale (display shows warning at 110% and above)		
Weight (lb [kg])	M7-012 - M7-100: 1.0 [0.45] M7-200 - M7-500: 1.2 [0.54]	M5-012 - M5-100: 1.0 [0.45] M5-200 - M5-500: 1.2 [0.54] M5-750 - M5-2000: 1.8 [0.82]	M4-012 - M4-100: 1.0 [0.45] M4-200 - M4-500: 1.2 [0.54]
Included items	Carrying case, chisel, cone, V-groove, hook, flat, extension rod, universal voltage AC adapter/charger, rechargeable battery, quick-start guide, USB cable, NIST-traceable certificate of calibration with data. Download free MESUR® Lite or MESUR®gauge Plus demo period at www.mark-10.com/software .		

* With configurable automatic data output, data storage, and zero function upon event completion. Can also stop travel of certain motorized test stands.

** Can stop certain legacy motorized test stands upon event completion.



 Series 3 Basic		 Series 2 Economical		
±0.3%		±0.5%		Accuracy (% of full scale)
2,000 Hz		500 Hz		Sampling rate
1/1,000				Resolution
USB		USB		Outputs
No		N/A		RS-232
Configurable up to 115,200 baud		N/A		USB
No		N/A		Mitutoyo (Digimatic)
No		N/A		Analog
No		N/A		General purpose I/O
No		N/A		Set point
Yes		N/A		MESUR® Lite software included
By pressing DATA button, or requesting from a PC or other device (currently displayed reading only)				Data output functionality
"?" only (request current reading)				ASCII command set for external control
Single point or continuous data output only				Interface w/MESUR® gauge and MESUR® Lite
No		No		Interface w/ESM303 / 750 / 1500 test stands
No				Data memory (readings, with output)
N/A				Data memory deletion
N/A				Statistic calculations and output to PC
No				Break detection
No				1st / 2nd peak detection
No				Programmable footswitch command string
No		No		Averaging mode
No		No		External trigger mode
Yes		No		Analog load bar graph shown on display
Yes with high/low indicators, markers on analog bar graph, no output		No		Set points (for pass / fail indication)
No				Password protection
Yes		No (Peak mode must be selected)		Peak readings always displayed
Yes		No		Programmable audible tones
Configurable number of data points (up to 10 in each direction)				Calibration procedure
No		No		Overload outputs
Rechargeable. Backlight on: up to 7 hours of continuous use / Backlight off: up to 24 hours of continuous use				Battery life
lbF, gf, kgF, N (depending on model)		lbF, kgF, N		Units of measurement
150% of full scale (display shows warning at 110% and above)				Safe overload
M3-012 - M3-100: 0.7 [0.33] M3-200 - M3-500: 0.9 [0.41]		M2-2 - M2-100: 0.7 [0.33] M2-200 - M2-500: 0.9 [0.41]		Weight (lb [kg])
Carrying case, chisel, cone, V-groove, hook, flat, extension rod, universal voltage AC adapter/charger, rechargeable battery, quick-start guide, USB cable, NIST-traceable certificate of calibration without data. Download free MESUR® Lite or MESUR®gauge Plus demo period at www.mark-10.com/software .		Carrying case, rechargeable battery, quick-start guide, USB cable, certificate of conformance. Download free MESUR® Lite or MESUR®gauge Plus demo period at www.mark-10.com/software .		Included items



Ordering Information

Model No.	Capacity x Resolution							
	lbF	ozF	kgF	gF	N	kN	mN	
Series 7	M7-012	0.12 x 0.00002	2 x 0.0005	-	50 x 0.01	0.5 x 0.0001	-	500 x 0.1
	M7-025	0.25 x 0.00005	4 x 0.001	-	100 x 0.02	1 x 0.0002	-	1000 x 0.2
	M7-05	0.5 x 0.0001	8 x 0.002	-	250 x 0.05	2.5 x 0.0005	-	2500 x 0.5
	M7-2	2 x 0.0005	32 x 0.01	1 x 0.0002	1000 x 0.2	10 x 0.002	-	-
	M7-5	5 x 0.001	80 x 0.02	2.5 x 0.0005	2500 x 0.5	25 x 0.005	-	-
	M7-10	10 x 0.002	160 x 0.05	5 x 0.001	5000 x 1	50 x 0.01	-	-
	M7-20	20 x 0.005	320 x 0.1	10 x 0.002	10000 x 2	100 x 0.02	-	-
	M7-50	50 x 0.01	800 x 0.2	25 x 0.005	25000 x 5	250 x 0.05	-	-
	M7-100	100 x 0.02	1600 x 0.5	50 x 0.01	50000 x 10	500 x 0.1	-	-
	M7-200	200 x 0.05	3200 x 1	100 x 0.02	-	1000 x 0.2	1 x 0.0002	-
	M7-500	500 x 0.1	8000 x 2	250 x 0.05	-	2500 x 0.5	2.5 x 0.0005	-
Series 5	M5-012	0.12 x 0.00002	2 x 0.0005	-	50 x 0.01	0.5 x 0.0001	-	500 x 0.1
	M5-025	0.25 x 0.00005	4 x 0.001	-	100 x 0.02	1 x 0.0002	-	1000 x 0.2
	M5-05	0.5 x 0.0001	8 x 0.002	-	250 x 0.05	2.5 x 0.0005	-	2500 x 0.5
	M5-2	2 x 0.0005	32 x 0.01	1 x 0.0002	1000 x 0.2	10 x 0.002	-	-
	M5-5	5 x 0.001	80 x 0.02	2.5 x 0.0005	2500 x 0.5	25 x 0.005	-	-
	M5-10	10 x 0.002	160 x 0.05	5 x 0.001	5000 x 1	50 x 0.01	-	-
	M5-20	20 x 0.005	320 x 0.1	10 x 0.002	10000 x 2	100 x 0.02	-	-
	M5-50	50 x 0.01	800 x 0.2	25 x 0.005	25000 x 5	250 x 0.05	-	-
	M5-100	100 x 0.02	1600 x 0.5	50 x 0.01	50000 x 10	500 x 0.1	-	-
	M5-200	200 x 0.05	3200 x 1	100 x 0.02	-	1000 x 0.2	1 x 0.0002	-
	M5-300	300 x 0.1	4800 x 2	150 x 0.05	-	1500 x 0.5	1.5 x 0.0005	-
	M5-500	500 x 0.1	8000 x 2	250 x 0.05	-	2500 x 0.5	2.5 x 0.0005	-
	M5-750	750 x 0.5	12000 x 10	375 x 0.2	-	3750 x 2	3.75 x 0.002	-
	M5-1000	1000 x 0.5	16000 x 5	500 x 0.2	-	5000 x 2	5 x 0.002	-
	M5-1500	1500 x 1	24000 x 20	750 x 0.5	-	7500 x 5	7.5 x 0.005	-
M5-2000	2000 x 1	32000 x 20	1000 x 0.5	-	10000 x 5	10 x 0.005	-	
Series 4	M4-012	0.12 x 0.00005	2 x 0.001	-	50 x 0.02	0.5 x 0.0002	-	500 x 0.2
	M4-025	0.25 x 0.0001	4 x 0.002	-	100 x 0.05	1 x 0.0005	-	1000 x 0.5
	M4-05	0.5 x 0.0002	8 x 0.005	-	250 x 0.1	2.5 x 0.001	-	2500 x 1
	M4-2	2 x 0.001	32 x 0.02	1 x 0.0005	1000 x 0.5	10 x 0.005	-	-
	M4-5	5 x 0.002	80 x 0.05	2.5 x 0.001	2500 x 1	25 x 0.01	-	-
	M4-10	10 x 0.005	160 x 0.1	5 x 0.002	5000 x 2	50 x 0.02	-	-
	M4-20	20 x 0.01	320 x 0.2	10 x 0.005	10000 x 5	100 x 0.05	-	-
	M4-50	50 x 0.02	800 x 0.5	25 x 0.01	25000 x 10	250 x 0.1	-	-
	M4-100	100 x 0.05	1600 x 1	50 x 0.02	50000 x 20	500 x 0.2	-	-
	M4-200	200 x 0.1	3200 x 2	100 x 0.05	-	1000 x 0.5	1 x 0.0005	-
	M4-500	500 x 0.2	8000 x 5	250 x 0.1	-	2500 x 1	2.5 x 0.001	-





Model No.	Capacity x Resolution				
	lbF	kgF	gF	N	
Series 3	M3-012	0.12 x 0.0001	-	50 x 0.05	0.5 x 0.0005
	M3-025	0.25 x 0.0002	-	100 x 0.1	1 x 0.001
	M3-05	0.5 x 0.0005	-	250 x 0.2	2.5 x 0.002
	M3-2	2 x 0.002	1 x 0.001	-	10 x 0.01
	M3-5	5 x 0.005	2.5 x 0.002	-	25 x 0.02
	M3-10	10 x 0.01	5 x 0.005	-	50 x 0.05
	M3-20	20 x 0.02	10 x 0.01	-	100 x 0.1
	M3-50	50 x 0.05	25 x 0.02	-	250 x 0.2
	M3-100	100 x 0.1	50 x 0.05	-	500 x 0.5
	M3-200	200 x 0.2	100 x 0.1	-	1000 x 1
	M3-500	500 x 0.5	250 x 0.2	-	2500 x 2
Series 2	M2-2	2 x 0.002	1 x 0.001	-	10 x 0.01
	M2-5	5 x 0.005	2.5 x 0.002	-	25 x 0.02
	M2-10	10 x 0.01	5 x 0.005	-	50 x 0.05
	M2-20	20 x 0.02	10 x 0.01	-	100 x 0.1
	M2-50	50 x 0.05	25 x 0.02	-	250 x 0.2
	M2-100	100 x 0.1	50 x 0.05	-	500 x 0.5
	M2-200	200 x 0.2	100 x 0.1	-	1000 x 1
	M2-500	500 x 0.5	250 x 0.2	-	2500 x 2



All models include 110V AC adapters

Add suffix 'E' for euro plug (220V), 'U' for UK plug (220V) or 'A' for Australian plug (220V)

Example: M5-05E, M3-20U, M2-100A



Series TT01

Cap Torque Testers

Series TT01 cap torque testers provide closure manufacturers, bottlers, and food and beverage companies an accurate and simple way to measure application and removal torques. Adjustable posts grip a broad range of container shapes and sizes, while sets of optional jaws are available as an alternative gripping methods. Peak torque readings are always shown on the large, backlit graphic display.

Features:

■ **USB, RS-232, Mitutoyo, and analog outputs**

■ **Data memory**

1,000-point data memory with statistics (min, max, mean, standard deviation), and outputs.

■ **Set point indicators with outputs**

Convenient for pass/fail testing.

■ **Automatic data output / save / zero**

Upon peak torque detection.

■ **1st / 2nd peak detection**

For slip and breakaway torques in tamper-evident closures.



Series TT02

Torque Tool Testers

Series TT02 torque tool testers present a simple yet accurate solution for testing torque screwdrivers, wrenches, and other tools. The TT02 features a solid aluminum housing, making it rugged enough for many years of service in production or laboratory use, while a universal receptacle with square drive and grooves accepts common bits and attachments. 1st / 2nd peak detection is provided for click-type tools.

Features:

■ **USB, RS-232, Mitutoyo, and analog outputs**

■ **Data memory**

1,000-point data memory with statistics (min, max, mean, standard deviation), and outputs.

■ **Set point indicators with outputs**

Convenient for pass/fail testing.

■ **Automatic data output / save / zero**

Upon peak torque detection.

■ **1st / 2nd peak detection**

For slip and breakaway torques in tamper-evident closures.



Series TT03 Torque Gauges

Series TT03 digital torque gauges are designed for clockwise and counter-clockwise torque testing applications in virtually every industry, with capacities from 10 ozFin to 100 lbFin (7 to 1,150 Ncm). A dedicated remote torque sensor with Jacobs chuck can be used to grip a sample, bit, or fixture. The gauges' rugged aluminum housing allows for hand-held use or test stand mounting for more sophisticated testing requirements.

Features:

- **Rugged, compact design**
Indicator and remote sensor with Jacobs chuck. Can be hand-held or mounted to a test stand.
- **USB data output**
Continuous or individual readings may be output to a PC through included USB output.
- **Set point indicators**
High, low, and in-range indicators are displayed according to programmed upper and lower set points.
- **Analog load bar**
Provides visual representation of applied load, and helps provide feedback for an imminent overload condition.



Series TT05 Torque Testers

Series TT05 universal torque testers can be used for a range of applications up to 100 lbFin [11.5 Nm]. The stainless steel loading surface features a matrix of threaded holes, ideal for accommodating specialized fixtures and attachments. The testers' rugged design and simple, intuitive operation allow for use in laboratory and production environments. Technical specifications and functionality are the same as with Series TT01.

Features:

- **Stainless steel loading plate with threaded holes**
Accommodates specialized fixtures and attachments.
- **USB, RS-232, Mitutoyo, and analog outputs**
- **Data memory**
1,000-point data memory with statistics (min, max, mean, standard deviation), and outputs.
- **Set point indicators with outputs**
Convenient for pass/fail testing.
- **Automatic data output / save / zero**
Upon peak torque detection.



Specifications



	TT01	TT05	TT02	TT03
Accuracy (% of full scale)	±0.3%	±0.3%	±0.3%	±0.5%
Password protection	Yes			No
Sampling rate	7,000 Hz			2,000 Hz
Resolution	1/1,000			
Outputs	USB, RS-232 Mitutoyo, Analog			USB
USB / RS-232	Configurable up to 115,200 baud			
Mitutoyo (Digimatic)	Serial BCD suitable for all Mitutoyo SPC-compatible devices			N/A
Analog	±1 VDC, ±2% FS. + for compression / CW, - for tension / CCW			N/A
General purpose I/O	Three open drain outputs, one input			N/A
Set point	Yes, three open drain lines			No
MESUR Lite software included	Yes			
Communication with MESUR gauge and MESUR Lite software	Single point or continuous data, send from gauge or request from software			
Data memory	1,000 readings, with output			No
Data memory deletion	Individual data points, or clear all			N/A
Statistics calculations	Max, min, mean, std. dev., number of readings, with output			N/A
Analog load bar graph shown on display	Yes			
Keypad password protection	Yes, for calibration and keys			No
Peak readings calculated	Yes			
Break detection*	Yes			No
1st / 2nd peak detection*	Yes			No
Programmable audible tones	Yes			
No. of units of measurement	5			3
Battery life (with backlight on/off)	Backlight on: up to 7 hours of continuous use, Backlight off: up to 24 hours of continuous use			
Safe overload	150% of full scale (display shows "OVER" at 110% and above)			
Weight (lb [kg])	8.4 [3.8]	10.9 [4.9]	5.8 [2.6]	1.8 [0.8]
Included items	1/4" hex to 3/8" square adapter (TT02 Only), carrying case (TT03 only) universal voltage AC adapter, battery, quick-start guide, and certificate of calibration. Download free MESUR Lite or MESUR Gauge demo period at mark-10.com/software .			

* With configurable automatic data output, data storage, and zero function upon detection of peak value(s).



Ordering Information

Model No.		Capacity x Resolution					
		ozFin	lbFin	kgFcm	kgFmm	Ncm	Nm
TT01	MTT01-12	192 x 0.1	12 x 0.005	14 x 0.01	-	135 x 0.1	1.35 x 0.001
	MTT01-25	400 x 0.2	25 x 0.01	28 x 0.02	-	290 x 0.2	2.9 x 0.002
	MTT01-50	800 x 0.5	50 x 0.02	58 x 0.05	-	570 x 0.5	5.7 x 0.005
	MTT01-100	1600 x 1	100 x 0.05	116 x 0.1	-	1150 x 1	11.5 x 0.01
TT02	MTT02-12	192 x 0.1	12 x 0.005	14 x 0.01	-	135 x 0.1	1.35 x 0.001
	MTT02-25	400 x 0.2	25 x 0.01	28 x 0.02	-	290 x 0.2	2.9 x 0.002
	MTT02-50	800 x 0.5	50 x 0.02	58 x 0.05	-	570 x 0.5	5.7 x 0.005
	MTT02-100	1600 x 1	100 x 0.05	116 x 0.1	-	1150 x 1	11.5 x 0.01
TT03	MTT03-10Z	10 x 0.01	-	-	7 x 0.005	7 x 0.005	-
	MTT03-20Z	20 x 0.02	-	-	14 x 0.01	14 x 0.01	-
	MTT03-50Z	50 x 0.05	-	-	36 x 0.05	36 x 0.05	-
	MTT03-12	192 x 0.2	12 x 0.01	-	-	135 x 0.1	-
	MTT03-50	800 x 1	50 x 0.05	-	-	570 x 0.5	-
	MTT03-100	1600 x 2	100 x 0.1	-	-	1150 x 1	-
TT05	MTT05-12	192 x 0.1	12 x 0.005	14 x 0.01	-	135 x 0.1	1.35 x 0.001
	MTT05-25	400 x 0.2	25 x 0.01	28 x 0.02	-	290 x 0.2	2.9 x 0.002
	MTT05-50	800 x 0.5	50 x 0.02	58 x 0.05	-	570 x 0.5	5.7 x 0.005
	MTT05-100	1600 x 1	100 x 0.05	58 x 0.05	-	1150 x 1	11.5 x 0.01

All models include 110V AC adapters

Add suffix 'E' for euro plug (220V), 'U' for UK plug (220V) or 'A' for Australian plug (220V)

Example: MTT01-50E, MTT02-100U, MTT03-50ZA





Measure force and torque with interchangeable indicators and remote sensors

Models M7I, M5I, and M3I force / torque indicators are designed for use with Mark-10's Plug & Test® remote force and torque sensors. All calibration and configuration data is saved within the sensors' smart connectors - not the indicator - allowing for true interchangeability. Each sensor series is available in a range of capacities, from 0.25 to 10,000 lbF (1 N to 50 kN) full scale and from 10 ozFin to 5,000 lbFin (7 Ncm to 550 Nm) full scale. Sensor details are provided on the following pages.





Torque Sensors

1 Series R50

Universal torque sensors, fixed chuck

Measure bidirectional torque for a wide variety of applications. Contain a chuck for up to 1/2" diameter samples. Sensors can be used as hand held devices, or mounted to a torque test stand. Capacities available from 10 ozFin to 100 lbFin [7 to 1,150 Ncm].

2 Series R51

Universal torque sensors, interchangeable chucks

A great solution for general bidirectional torque testing applications with several different sample sizes. Three interchangeable chuck capacities and bit holder are available. The R51 has super overload protection and is available in capacities from 10 ozFin to 100 lbFin [7 to 1,150 Ncm].

3 Series R55

Wrench extension torque sensors

Convert any wrench to a torque tool with this sensor series, or use it as a component of a torque testing system. Capacities available from 20 to 5,000 lbFin [220 Ncm to 550 Nm].

4 Series R52

Static torque sensors

Calibrate torque tools with these sensors, or use them as components of a torque testing system. Tapped holes on every surface allow for easy mounting to a work bench or fixture. Capacities available from 10 ozFin to 100 lbFin [7 to 1,150 Ncm].

Force Sensors

5 Series R01

Tension / compression sensors

Rugged sensor series for measuring tensile and compressive force of up to 10,000 lbF [50 kN]. Durable S-beam design with thread on two sides.

6 Series R03

Inline tension / compression sensors

Measure tensile and compressive loads for a wide variety of applications, available in capacities from 0.25 lbF to 100 lbF [1 to 500 N]. Thread on two sides can accept a variety of hooks and implements, making this sensor series particularly well suited for inline tests.

7 Series R04

Miniature tension / compression sensors

Extremely compact force measurement sensors for tensile and compressive loads in applications with limited space. Capacities available from 0.25 lbF to 100 lbF. [1 to 500 N] The sensors include threaded holes on two sides for the mounting of attachments.

8 Series R02

Compact compression sensors

Button type sensors for compressive loads of up to 10,000 lbF [50 kN]. Compact, rugged, and ideal for heavy duty applications with space constraints.

9 Series R05

Pull / tension sensor

Fully enclosed force sensor for tension and compression testing. Useful in ergonomics testing, workplace safety testing, and general lifting or push/pull requirements. For up to 500 lbF [2,500 N] of force.



10 Series R06

Wire crimp pull sensor

Hand-operated solution for wire crimp pull-off force measurement. Ergonomic handles and convenient tensioning mechanism ideal for field measurements up to 200 lbF [1 kN].



Specifications - Force and Torque Indicators

	 Model M71 Professional	 Model M51 Advanced	 Model M31 Basic
Accuracy (% of full scale)	±0.1 + sensor		±0.2% + sensor
Sensor password protection	Yes		No
Sampling rate	14,000 Hz	7,000 Hz	2,000 Hz
Resolution	1/2,000 or 1/1,000, depending on sensor		1/1,000
Outputs	USB, RS-232, Mitutoyo, Analog		USB
RS-232	Configurable up to 230,400 baud	Configurable up to 115,200 baud	No
USB	Configurable up to 230,400 baud	Configurable up to 115,200 baud	
Mitutoyo (Digimatic)	Serial BCD suitable for all Mitutoyo SPC-compatible devices		No
Analog	±1 VDC, ±2% FS, + for compression / CW, - for tension / CCW		No
General purpose I/O	Three open drain outputs, one input		No
Set point	Three open drain lines		No
MESUR® Lite software included	Yes		
Data output functionality	Automatic output or by pressing DATA button, or requesting from a PC or other device		By pressing DATA button, or requesting from a PC or other device (currently displayed reading only)
ASCII command set for external control	Full command set		"?" only (request current reading)
Communication with MESUR® gauge and MESUR® Lite software	Full communication		Send single reading from gauge only, cannot request from software
Communication with ESM301 test stand and Series DC test stand controllers	Full communication, including PC control		No
Data memory	5,000 readings, with output	1,000 readings, with output	No
Data memory deletion	Individual data points, or clear all		N/A
Statistics calculations and output to PC	Max, min, mean, std. dev., number of readings, with output		No
Break detection	Yes*		No
1st / 2nd peak detection	Yes*		No
Programmable footswitch command string	Yes*		No
Averaging mode	Yes*	Yes	No
External trigger mode	Yes**	Yes	No
Analog load bar graph shown on display	Yes		
Set points (for pass/fail indication)	Yes, with high/low indicators		
Keypad password protection	Yes, for calibration and keys		No
Peak readings always displayed	Yes		
Programmable audible tones	Yes		
Calibration procedure	Configurable number of data points (up to 10 in each direction)		
Overload outputs	Dedicated pins for tension and compression		No
No. of units of measurement	5		3
Battery life (with backlight on/off)	Up to 7 hours of continuous use / Up to 24 hours of continuous use		
Weight	0.7 lb [0.3 kg]		
Included items	Carrying case, universal voltage AC adapter, battery, quick-start guide, USB cable, and certificate of conformance. Download free MESUR® Lite or MESUR® Gauge demo period at mark-10.com/software .		

* With configurable automatic data output, data storage, and zero function upon event completion. Can also stop travel of certain motorized test stands.

** Can stop travel of certain motorized test stands upon event completion.



Ordering Information - Force Sensors

Model No.	Capacity x Resolution - with Model 7I & 5I indicators						Capacity x Resolution - with Model 3I indicator				Accuracy* (±% FS)	Safe Overload	
	lbF	ozF	gF	kgF	N	kN	lbF	kgF	N	kN			
R01**	MR01-50	50 x 0.02	800 x 0.5	25000 x 10	25 x 0.01	250 x 0.1	-	50 x 0.05	25 x 0.02	250 x 0.2	-	0.15%	150%
	MR01-100	100 x 0.05	1600 x 1	50000 x 20	50 x 0.02	500 x 0.2	-	100 x 0.1	50 x 0.05	500 x 0.5	-		
	MR01-200	200 x 0.1	3200 x 2	-	100 x 0.05	1000 x 0.5	1 x 0.0005	200 x 0.2	100 x 0.1	1000 x 1	-		
	MR01-300	300 x 0.2	4800 x 5	-	150 x 0.1	1500 x 1	1.5 x 0.001	300 x 0.5	150 x 0.2	1500 x 2	-		
	MR01-500	500 x 0.2	8000 x 5	-	250 x 0.1	2500 x 1	2.5 x 0.001	500 x 0.5	250 x 0.2	2500 x 2	-		
	MR01-1000	1000 x 0.5	16000 x 10	-	500 x 0.2	5000 x 2	5 x 0.002	1000 x 1	500 x 0.5	5000 x 5	-		
	MR01-1500	1500 x 1	24000 x 20	-	750 x 0.5	7500 x 5	7.5 x 0.005	1500 x 2	750 x 1	7500 x 10	-		
	MR01-2000	2000 x 1	32000 x 20	-	1000 x 0.5	10000 x 5	10 x 0.005	2000 x 2	1000 x 1	10000 x 10	-		
	MR01-5000	5000 x 2	-	-	2500 x 1	25000 x 10	25 x 0.01	5000 x 5	2500 x 2	-	25 x 0.02		
	MR01-10000	10000 x 5	-	-	5000 x 2	50000 x 25	50 x 0.02	10000 x 10	5000 x 5	-	50 x 0.05		
R02	MR02-100	100 x 0.05	1600 x 1	50000 x 20	50 x 0.02	500 x 0.2	-	100 x 0.1	50 x 0.05	500 x 0.5	-	0.5%	150%
	MR02-200	200 x 0.1	3200 x 2	-	100 x 0.05	1000 x 0.5	1 x 0.0005	200 x 0.2	100 x 0.1	1000 x 1	-		
	MR02-500	500 x 0.2	8000 x 5	-	250 x 0.1	2500 x 1	2.5 x 0.001	500 x 0.5	250 x 0.2	2500 x 2	-		
	MR02-1000	1000 x 0.5	16000 x 10	-	500 x 0.2	5000 x 2	5 x 0.002	1000 x 1	500 x 0.5	5000 x 5	-		
	MR02-2000	2000 x 1	32000 x 20	-	1000 x 0.5	10000 x 5	10 x 0.005	2000 x 2	1000 x 1	10000 x 10	-		
	MR02-5000	5000 x 2	-	-	2500 x 1	25000 x 10	25 x 0.01	5000 x 5	2500 x 2	-	25 x 0.02		
	MR02-10000	10000 x 5	-	-	5000 x 2	50000 x 25	50 x 0.02	10000 x 10	5000 x 5	-	50 x 0.05		
R03**	MR03-025	0.25 x 0.0001	4 x 0.002	100 x 0.05	-	1 x 0.0005	1000 x 0.5 mN	0.25 x 0.0002	100 x 0.1 gF	1 x 0.001	-	0.15%	200%
	MR03-05	0.5 x 0.0002	8 x 0.005	250 x 0.1	-	2.5 x 0.001	2500 x 1 mN	0.5 x 0.0005	250 x 0.2 gF	2.5 x 0.002	-		
	MR03-2	2 x 0.001	32 x 0.02	1000 x 0.5	1 x 0.0005	10 x 0.005	-	2 x 0.002	1 x 0.001	10 x 0.01	-		
	MR03-5	5 x 0.002	80 x 0.05	2500 x 1	2.5 x 0.001	25 x 0.01	-	5 x 0.005	2.5 x 0.002	25 x 0.02	-		
	MR03-10	10 x 0.005	160 x 0.1	5000 x 2	5 x 0.002	50 x 0.02	-	10 x 0.01	5 x 0.005	50 x 0.05	-		150%
	MR03-20	20 x 0.01	320 x 0.2	10000 x 5	10 x 0.005	100 x 0.05	-	20 x 0.02	10 x 0.01	100 x 0.1	-		
	MR03-50	50 x 0.02	800 x 0.5	25000 x 10	25 x 0.01	250 x 0.1	-	50 x 0.05	25 x 0.02	250 x 0.2	-		
	MR03-100	100 x 0.05	1600 x 1	50000 x 20	50 x 0.02	500 x 0.2	-	100 x 0.1	50 x 0.05	500 x 0.5	-		
R04	MR04-025	0.25 x 0.0001	4 x 0.002	100 x 0.05	-	1 x 0.0005	1000 x 0.5 mN	0.25 x 0.0002	100 x 0.1 gF	1 x 0.001	-	0.2%	200%
	MR04-05	0.5 x 0.0002	8 x 0.005	250 x 0.1	-	2.5 x 0.001	2500 x 1 mN	0.5 x 0.0005	250 x 0.2 gF	2.5 x 0.002	-		
	MR04-2	2 x 0.001	32 x 0.02	1000 x 0.5	1 x 0.0005	10 x 0.005	-	2 x 0.002	1 x 0.001	10 x 0.01	-		
	MR04-5	5 x 0.002	80 x 0.05	1000 x 0.5	2.5 x 0.001	25 x 0.01	-	5 x 0.005	2.5 x 0.002	25 x 0.02	-		
	MR04-10	10 x 0.005	160 x 0.1	5000 x 2	5 x 0.002	50 x 0.02	-	10 x 0.01	5 x 0.005	50 x 0.05	-		
	MR04-20	20 x 0.01	320 x 0.2	10000 x 5	10 x 0.005	100 x 0.05	-	20 x 0.02	10 x 0.01	100 x 0.1	-		
	MR04-50	50 x 0.02	800 x 0.5	25000 x 10	25 x 0.01	250 x 0.1	-	50 x 0.05	25 x 0.02	250 x 0.2	-		
	MR04-100	100 x 0.05	1600 x 1	50000 x 20	50 x 0.02	500 x 0.2	-	100 x 0.1	50 x 0.05	500 x 0.5	-		
R05	MR05-500	500 x 0.2	8000 x 5	-	250 x 0.1	2500 x 1	2.5 x 0.001	500 x 0.5	250 x 0.2	2500 x 2	-	0.15%	150%
R06	MR06-200	200 x 0.1	3200 x 2	-	100 x 0.05	1000 x 0.5	1 x 0.0005	200 x 0.2	100 x 0.1	1000 x 1	-	0.5%	150%

All sensors include a Plug & Test® connector for interfacing directly with an M7I, M5I or M3I indicator. NIST-traceable certificate of calibration with data is also included.

* Accuracy refers to the sensor only. Total accuracy includes the indicator's accuracy (±0.1% or ±0.2%). For example, the total accuracy of the MR50-50 sensor with M5I indicator equals ±0.35% + ±0.1% = ±0.45% FS.

** Add suffix "-1" for shortened cable, for use on ESM303(H), ESM750, and ESM1500 test stands. Ex: MR01-1000-1. Test stand mounting hardware is included.



Ordering Information - Torque Sensors

Model No.	Capacity x Resolution with Model M7I & M5I indicators								Capacity x Resolution with Model M3I indicator				Accuracy * (±% FS)	Safe Overload	
	ozFin	lbFin	lbFft	gFcm	kgFmm	Nmm	Ncm	Nm	ozFin	lbFin	kgFmm	Ncm			
R50	MR50-10Z	10 x 0.005	-	-	700 x 0.5	7 x 0.005	70 x 0.05	7 x 0.005	-	10 x 0.01	-	7 x 0.005	7 x 0.005	0.35%	300%
	MR50-20Z	20 x 0.01	-	-	1400 x 1	14 x 0.01	140 x 0.1	14 x 0.01	-	20 x 0.02	-	14 x 0.01	14 x 0.01		
	MR50-50Z	50 x 0.02	-	-	3600 x 2	36 x 0.02	350 x 0.2	35 x 0.02	-	50 x 0.05	-	36 x 0.05	35 x 0.05		
	MR50-12	192 x 0.1	12 x 0.005	1 x 0.0005	-	-	-	135 x 0.1	1.35 x 0.001	192 x 0.2	12 x 0.01	-	135 x 0.1		150%
	MR50-50	800 x 0.5	50 x 0.02	4 x 0.002	-	-	-	570 x 0.5	5.7 x 0.005	800 x 1	50 x 0.05	-	570 x 0.5		
	MR50-100	1600 x 1	100 x 0.05	8 x 0.005	-	-	-	1150 x 1	11.5 x 0.01	1600 x 2	100 x 0.1	-	1150 x 1		
R51	MR51-10Z	10 x 0.005	-	-	700 x 0.5	7 x 0.005	70 x 0.05	7 x 0.005	-	10 x 0.01	-	7 x 0.005	7 x 0.005	0.15%	300%
	MR51-20Z	20 x 0.01	-	-	1400 x 1	14 x 0.01	140 x 0.1	14 x 0.01	-	20 x 0.02	-	14 x 0.01	14 x 0.01		
	MR51-50Z	50 x 0.02	-	-	3600 x 2	36 x 0.02	350 x 0.2	35 x 0.02	-	50 x 0.05	-	36 x 0.05	35 x 0.05		
	MR51-12	192 x 0.1	12 x 0.005	1 x 0.0005	-	-	-	135 x 0.1	1.35 x 0.001	192 x 0.2	12 x 0.01	-	135 x 0.1		150%
	MR51-50	800 x 0.5	50 x 0.02	4 x 0.002	-	-	-	570 x 0.5	5.7 x 0.005	800 x 1	50 x 0.05	-	570 x 0.5		
	MR51-100	1600 x 1	100 x 0.05	8 x 0.005	-	-	-	1150 x 1	11.5 x 0.01	1600 x 2	100 x 0.1	-	1150 x 1		
R52	MR52-10Z	10 x 0.005	-	-	700 x 0.5	7 x 0.005	70 x 0.05	7 x 0.005	-	10 x 0.01	-	7 x 0.005	7 x 0.005	0.35%	300%
	MR52-20Z	20 x 0.01	-	-	1400 x 1	14 x 0.01	140 x 0.1	14 x 0.01	-	20 x 0.02	-	14 x 0.01	14 x 0.01		
	MR52-50Z	50 x 0.02	-	-	3600 x 2	36 x 0.02	350 x 0.2	35 x 0.02	-	50 x 0.05	-	36 x 0.05	35 x 0.05		
	MR52-12	192 x 0.1	12 x 0.005	1 x 0.0005	-	-	-	135 x 0.1	1.35 x 0.001	192 x 0.2	12 x 0.01	-	135 x 0.1		150%
	MR52-50	800 x 0.5	50 x 0.02	4 x 0.002	-	-	-	570 x 0.5	5.7 x 0.005	800 x 1	50 x 0.05	-	570 x 0.5		
	MR52-100	1600 x 1	100 x 0.05	8 x 0.005	-	-	-	1150 x 1	11.5 x 0.01	1600 x 2	100 x 0.1	-	1150 x 1		
R55	MR55-20	320 x 0.5	20 x 0.02	1.5 x 0.002	-	-	-	220 x 0.2	2 x 0.002	320 x 0.5	20 x 0.02	-	220 x 0.2	0.6%	150%
	MR55-50	800 x 1	50 x 0.05	4 x 0.005	-	-	-	570 x 0.5	5.7 x 0.005	800 x 1	50 x 0.05	-	570 x 0.5		
	MR55-100	1600 x 2	100 x 0.1	8 x 0.01	-	-	-	1150 x 1	11.5 x 0.01	1600 x 2	100 x 0.1	-	1150 x 1		
	MR55-200	-	200 x 0.2	16 x 0.02	-	2300 x 2	-	2200 x 2	22 x 0.02	-	200 x 0.2	2300 x 2	2200 x 2		
	MR55-400	-	400 x 0.5	32 x 0.05	-	4600 x 5	-	4500 x 5	45 x 0.05	-	400 x 0.5	4600 x 5	4500 x 5		
	MR55-1000	-	1000 x 1	80 x 0.1	-	11500 x 10	-	11000 x 10	110 x 0.1	-	1000 x 1	11500 x 10	11000 x 10		
	MR55-5000	-	5000 x 5	400 x 0.5	-	55 x 0.05 kgFm	-	55000 x 50	550 x 0.5	-	5000 x 5	55 x 0.05 kgFm	550 x 0.5 Nm		

All sensors include a Plug & Test® connector for interfacing directly with an M7I, M5I, or M3I indicator. NIST-traceable certificate of calibration with data is also included.

* Accuracy refers to the sensor only. Total accuracy includes the indicator's accuracy (±0.1% or ±0.2%).
Ex: the total accuracy of the MR50-50 sensor with M5I indicator equals ±0.35% + ±0.1% = ±0.45% FS.

** Add suffix "-1" for shortened cable, for use on ESM303(H), ESM750, and ESM1500 test stands.
Ex: MR01-1000-1. Test stand mousing hardware is included.



Series F Force Sensors



Series FS05

Tension and compression force sensors

Series FS05 force sensors measure tension and compression forces. They mount directly to the crosshead of models F105, F305, F505, and F505H test frames, for a clean, integrated look.

Compatible with Models F105, F305, F505, and F505H. Adapter part no. AC1083 is required for Models F755, F755S, F1505, and F1505S.



Series FS06

Tension and compression force sensors

Series FS06 force sensors measure tension and compression forces. Designed to accommodate bulkier grips and fixtures, they are compatible with Series F test frame models up to 500 lbf / 2.2 kN.

With Plug & Test® technology, all configuration and calibration data is saved within the sensor, allowing it to be calibrated on the test frame or off-site with a Mark-10 indicator (optional adapter AC1083 required).



Series R07

Tension and compression force sensors

Series MR07 force sensors measure tension and compression forces, and are designed for Series F test frames. With Plug & Test® technology, all configuration and calibration data is saved within the sensor, allowing it to be calibrated on the test frame or off-site with a Mark-10 indicator (optional adapter: AC1083 required).

Compatible with Models F755, F755S, F1505, and F1505S. Cannot be used with Models F105, F305, F505, and F505H.

Model PTA / PTAF

Connect common strain gage-based load cells, force sensors, and torque sensors to Models M7I, M5I and M3I indicators with this user-configurable adapter and software.

Sensor capacity and resolutions may be programmed via an included software utility, which includes a library of common force capacities from 0.12 to 750,000 lbF (0.5 N to 4,000 kN), and torque capacities from 10 ozFin to 40,000 lbFft (7 Ncm to 57,000 Nm).

An identification number may be programmed, which is displayed upon indicator power-up or the indicator's Information screen. Through Plug & Test® technology, all configuration and calibration information is saved within the adapter. This flexibility allows for interchangeability between multiple sensors with any Mark-10 indicator.

Features:

- **Compatible with strain gage-based load cells, force sensors, and torque sensors**
- **Screw terminal block allows for easy connection of sensor wires**
- **Software configuration utility is included, for easy programming of sensor capacity, resolution, and identification number**
- **Program the adapter via USB or RS-232 through the indicator**
- **Mounting holes for bench mounting**

Model No.	Description
PTA	Plug and Test® adapter
PTAF	Adapter, customer-supplied sensor to Models F105 / F305 / F505 / F505H test frames

Sensor Requirements:

Type: Full bridge

Resistance: 300 - 1,000 ohms

Sensitivity: 1-3 mV/V

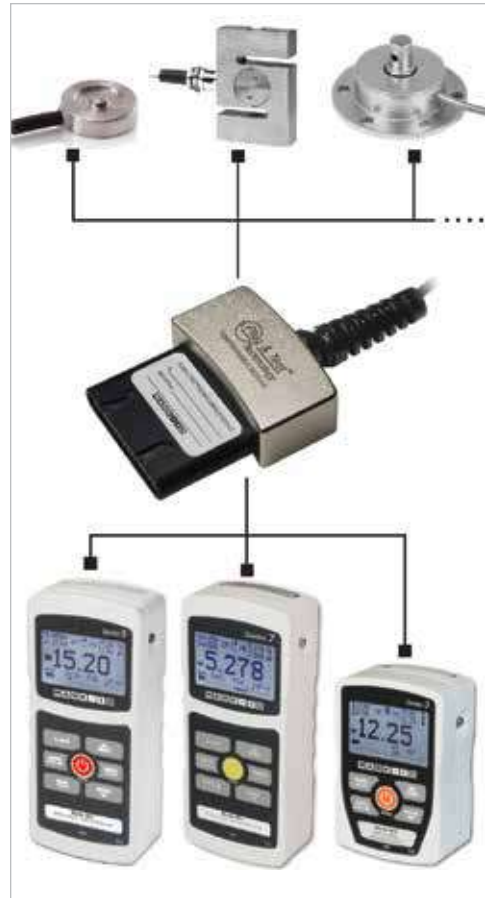

PTA



PTAF



Ordering Information - Series F Force Sensors

Model No.	Capacity x Resolution							Accuracy * (±% FS)	Safe Overload	
	lbF	ozF	gF	kgF	N	kN	mN			
FS05	FS05-012	0.12 x 0.00005	2 x 0.001	50 x 0.02	-	0.5 x 0.0002	-	500 x 0.2	0.1%	150%
	FS05-025	0.25 x 0.0001	4 x 0.002	100 x 0.05	-	1 x 0.0005	-	1000 x 0.5		
	FS05-05	0.5 x 0.0002	8 x 0.005	250 x 0.1	-	2.5 x 0.001	-	2500 x 1		
	FS05-2	2 x 0.001	32 x 0.02	1000 x 0.5	1 x 0.0005	10 x 0.005	-	-		
	FS05-5	5 x 0.002	80 x 0.05	2500 x 1	2.5 x 0.001	25 x 0.01	-	-		
	FS05-10	10 x 0.005	160 x 0.1	5000 x 2	5 x 0.002	50 x 0.02	-	-		
	FS05-20	20 x 0.01	320 x 0.2	10000 x 5	10 x 0.005	100 x 0.05	-	-		
	FS05-50	50 x 0.02	800 x 0.5	25000 x 10	25 x 0.01	250 x 0.1	-	-		
	FS05-100	100 x 0.05	1600 x 1	50000 x 20	50 x 0.02	500 x 0.2	-	-		
	FS05-200	200 x 0.1	3200 x 2	-	100 x 0.05	1000 x 0.5	1 x 0.0005	-		
	FS05-300	300 x 0.1	4800 x 2	-	150 x 0.05	1500 x 0.5	1.5 x 0.0005	-		
	FS05-500	500 x 0.2	8000 x 5	-	250 x 0.1	2500 x 1	2.5 x 0.001	-		
	FS06-50	50 x 0.02	800 x 0.5	25000 x 10	25 x 0.01	250 x 0.1	-	-		
FS06	FS06-100	100 x 0.05	1600 x 1	50000 x 20	50 x 0.02	500 x 0.2	-	-		
	FS06-200	200 x 0.1	3200 x 2	-	100 x 0.05	1000 x 0.5	1 x 0.0005	-		
	FS06-300	300 x 0.2	4800 x 5	-	150 x 0.1	1500 x 1	1.5 x 0.001	-		
	FS06-500	500 x 0.2	8000 x 5	-	250 x 0.1	2500 x 1	2.5 x 0.001	-		
R07	MR07-50	50 x 0.02	800 x 0.5	25000 x 10	25 x 0.01	250 x 0.1	-	-	0.15%	150%
	MR07-100	100 x 0.05	1600 x 1	50000 x 20	50 x 0.02	500 x 0.2	-	-		
	MR07-200	200 x 0.1	3200 x 2	-	100 x 0.05	1000 x 0.5	1 x 0.0005	-		
	MR07-300	300 x 0.2	4800 x 5	-	150 x 0.1	1500 x 1	1.5 x 0.001	-		
	MR07-500	500 x 0.2	8000 x 5	-	250 x 0.1	2500 x 1	2.5 x 0.001	-		
	MR07-750	750 x 0.5	12000 x 10	-	375 x 0.2	3750 x 2	3.75 x 0.002	-		
	MR07-1000	1000 x 0.5	16000 x 10	-	500 x 0.2	5000 x 2	5 x 0.002	-		
	MR07-1500	1500 x 1	24000 x 20	-	750 x 0.5	7500 x 5	75 x 0.005	-		

All sensors include a NIST-traceable certificate of calibration with data.



Model WT3-201

Manual, 200 lbf / 1,000 N

The WT3-201 is an integrated solution for manual wire crimp pull testing requirements. An ergonomic lever allows for easy application of force. Adjustable terminal fixture contains multiple slots for diameters up to AWG 3 (0.25 in [6.3 mm]). USB output, data memory, and peak force capture are provided.

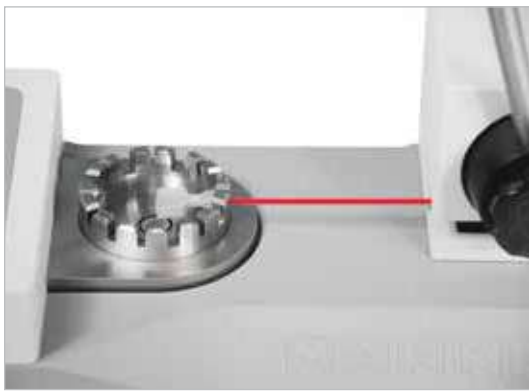

▲ Adjustable wire terminal fixture accommodates wire diameter sizes up to 0.25 in (6.3 mm).



▲ Unique knurled cam design effectively secures and pulls the loose end of the sample.



▲ Ergonomic lever easily applies force and releases the sample.

Features

- **Peak force capture**
- **USB, RS-232, Mitutoyo, and analog outputs**
- **Data memory**
1,000-point data memory with statistics (min, max, mean, standard deviation), and outputs.
- **Password protection**
Passwords may be set for calibration and for individual keys, designed to protect the tester against unauthorized changes.
- **Automatic output**
Automatic output / data storage / zeroing upon sample break helps automate testing processes

Ordering Information

Model No.	Description
WT3-201	Wire terminal tester, 110V
WT3-201E	Wire terminal tester, 220V EUR
WT3-201U	Wire terminal tester, 220V UK
WT3-201A	Wire terminal tester, 220V AUS
WT3001	Carrying case
WT3002	Ring terminal fixture
WT3003	Machinable blank terminal fixture
AC1049	Calibration kit



Model WT3-201M

Motorized, 200 lbf / 1,000 N

The WT3-201M is an integrated motorized solution for destructive and non-destructive wire crimp pull testing requirements, such as pulling to a load and load holding. Adjustable terminal fixture contains multiple slots for diameters up to AWG 3 (0.25 in [6.3 mm]). USB output, data memory with time stamp, and peak force capture are provided, along with the ability to save up to 500 test profiles.

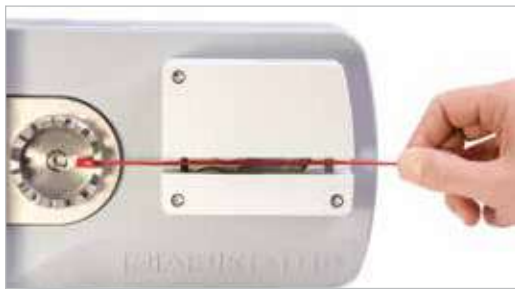

▲ The tester automatically starts when the sample is loaded, and returns to home when the sample breaks. Adjustable terminal fixture accommodates wire diameters up to 0.25 in (6.3 mm).



▲ As the test begins, serrated cams engage the sample. A pinch guard (red tab shown above) automatically rotates into position, for added safety.



▲ Save and recall multiple profiles, for quick and accurate switchover to different test methods.

Features

- Measures real-time and peak force values
- Selectable test speed, w/high speed approach and reverse
- Auto-start upon sample insertion
- Auto-reverse at sample break or load
- USB, RS-232, Mitutoyo, and analog outputs
- 2,000-point data memory with statistics, output, and date and time stamp
- Save and recall up to 500 test profiles
- Pull to a specified load or maintain load for a specified period of time, as per UL 486A/B

Ordering Information

Model No.	Description
Hardware	
WT3-201M	Motorized wire crimp pull tester, 110V
WT3-201ME	Motorized wire crimp pull tester, 220V EUR
WT3-201MU	Motorized wire crimp pull tester, 220V UK
WT3-201MA	Motorized wire crimp pull tester, 220V AUS
WT3002	Ring terminal fixture
WT3003	Machinable blank terminal fixture
WT3004	Carrying case
AC1049	Calibration kit
Optional Functions	
WF010	Profiles
WF011	Pull to load limit
WF012	Load holding
WF013	Date and time stamp
WFCOMP	Complete options package (includes all Controller Options)



Test push/pull muscle strength and functional task requirements



These force gauge kits are ideal for strength assessment, ergonomic studies, and workplace design. Available in capacities of 100 lbF (500 N), 200 lbF (1,000 N), and 500 lbF (2,500 N).

- **Series EK3** basic kits offer everyday functionality and include a selection of commonly used attachments.
- **Series E** offers increased force gauge performance, with unique Click-Lock® accessory mounting technology. Select pre-configured kits, or pick and choose a gauge and accessories suited to your unique applications.
- **Series EKM5** myometer kits are designed for muscle strength assessments, and include a Series 5 force gauge, strap and hook. A myometer accessory is also available for Series E.

Comparison Chart

	Series 3 (included w/Series EK3 kits)	Series E (included w/Series EKE kits)*
Accuracy	±0.3%	±0.2%
Sampling rate	2,000 Hz	7,000 Hz
Units of measurement	lbF, kgF, N	lbF, ozF, kgF, N, kN
USB data output	✓	✓
Averaging mode	✗	✓
On-board data memory & statistics	✗	✓
Continuous data capture	✗	✓
Accessory mounting	Traditional mounting threads	Click-Lock® Technology
Password protection	✗	✓
Available accessories:		
Single handle grip	✓	✓
Double handle grip	✓	✓
Padded attachment, curved	✓	✓
Padded attachment, flat	✓	✓
Padded attachment, square	✓	✓
Padded attachment, circular	✗	✓
Hook	Clevis grip	Snap hook
Chain / hook assembly	✗	✓
Pistol grip	✗	✓
MESUR® Lite software included	✓	✓



Series 3



Series EK3 kit



Series E



Series EKE kit

* Refer to the Series E data sheet for information about which accessories are included with each kit level.



Click-Lock® Technology - Series E



Attachments click and lock into place via innovative Click-Lock® technology, a rugged anti-rotation locking mechanism. The attachments may be clicked into 90° or 180° orientations. No fastening is required, as with conventional force gauges, reducing the risk of damage to the instrument.



Available Accessories - Series E



- | | |
|---|--------------------------------------|
| 1 E1010 pistol grip | 7 E1008 single handle grip |
| 2 E1002 padded attachment, square | 8 E1007 chain / hook assembly |
| 3 E1003 padded attachment, rectangular | 9 E1013 myometer accessory |
| 4 E1004 padded attachment, curved | 10 E1012 looped cable |
| 5 E1005 padded attachment, circular | 11 Series E force gauge |
| 6 E1009 double handle grip | 12 E1006 hook |

Ordering Information - Kits

Model No.	Description
EK3-100	Basic ergonomics testing kit, 100 lbF / 500 N
EK3-200	Basic ergonomics testing kit, 200 lbF / 1,000 N
EK3-500	Basic ergonomics testing kit, 500 lbF / 2,500 N
EKE-100-1	Advanced ergonomics kit, 100 lbF / 500 N
EKE-200-1	Advanced ergonomics kit, 200 lbF / 1,000 N
EKE-500-1	Advanced ergonomics kit, 500 lbF / 2,500 N
EKE-100-2	Professional ergonomics kit, 100 lbF / 500 N
EKE-200-2	Professional ergonomics kit, 200 lbF / 1,000 N
EKE-500-2	Professional ergonomics kit, 500 lbF / 2,500 N
EKM5-200	Myometer, complete kit w/M5-200 force gauge

All models include 110V AC adapters. Add suffix 'E' for euro plug (220V), 'U' for UK plug (220V), or 'A' for Australian plug (220V).

Example: EK3-100E, EKE-200-1U, EKM5-200A



Model ES05

Force, Manual, 30 lbF / 150 N

The ES05 test stand is an economical and compact compression-only test stand for various testing applications. A spring-loaded lever allows for repeatable testing with up to 1.5" (38 mm) displacement, and the lever mechanism can be repositioned along the length of the column.

Features

- **Spring loaded lever mechanism**
Convenient for repetitive testing.
- **Repositionable lever mechanism**
Adds flexibility in test setups.
- **Compact size**
Portable, small footprint.



Models ES10 and ES20

Force, Manual, 100 lbF / 500 N

The ES10 and ES20 test stands are economical and compact push/pull solutions for many testing applications. Available in lever (ES10) or hand wheel (ES20) operation.

Features

- **Choice of lever (ES10) or hand wheel (ES20) operation**
Lever action provides for quick testing at high speeds, while hand wheel action allows for fine positioning and better motion control.
- **Optional 1" dial or digital indicator (ES001, ES002)**
For spring testing, rubber and polymer testing, and more. Digital model displays in and mm. Also available as brackets only (no indicator).
- **Compact size**
Portable, small footprint.



ES001



ES002



Model ES30

Force, Manual, 200 lbF / 1,000 N

The ES30 accommodates a wide range of sample shapes and sizes due to generous travel distance, daylight, and throat distance. Convenient side-mounted hand wheel operation makes testing easier.

Features

- **Side mounted hand wheel**

Convenient loading method, offers more control over test speed.

- **Removable base**

The entire base may be removed for alternative mounting.

- **Optional digital travel displays (ESM001, ESM004)**

Useful in spring testing, rubber and polymer testing, and other applications. Select from 6" [152 mm] and 12" [305 mm] lengths.

- **Optional column extensions**

For testing long samples. Available in lengths of 6" [152 mm] (ESM003-1), 12" [305 mm] (ESM003-2), and 24" [610 mm] (ESM003-3). Custom lengths also available.



Model TSA750 / TSA750H

Force, Manual, 750 lbF / 3,750 N

The TSA750 is a rugged stand for heavy duty testing applications requiring quick action. Lever operation allows the operator to produce 750 lbF with relatively little effort. Modular design allows for the force gauge bracket and lever mechanism to be repositioned along the column. Available in vertical and horizontal configurations.

Features

- **Rack and pinion mechanism with lever operation**

Allows for quick testing. The lever can be repositioned in 30° increments.

- **Adjustable travel stops**

For limiting travel distance. Useful in repetitive testing.

- **Optional 6" [152 mm] digital travel display (TSA001)**

Useful in spring testing, rubber and polymer testing, and other applications.



TSA750



TSA750H



Model TSB100

Force, Manual, 100 lbF / 500 N

The TSB100 is a lever-operated test stand for many applications requiring quick action. Lightweight and compact design makes this stand portable for field testing. Modular design allows for the force gauge bracket and lever mechanism to be repositioned along the column. Removable base allows for a range of custom mounting configurations. Adjustable travel stops are available.

Features:

- **Rack and pinion mechanism with lever operation**
Allows for quick testing. The lever can be repositioned in 30° increments.
- **Removable base with loading table**
A steel loading table with threaded holes is provided for grip or fixture mounting. The entire base may be removed for alternative mounting.
- **Optional 6" [152 mm] digital travel display (TSB001)**
Useful in spring testing, rubber and polymer testing, and more.



TSC1000

Model TSC1000 / TSC1000H

Force, Manual, 1,000 lbF / 5,000 N

The TSC1000 is a rugged stand for heavy duty testing requirements requiring fine position control without back driving. Hand wheel operation allows the operator to produce gradual and repeatable force during testing. Modular design allows for the gauge mounting plate and housing to be moved along the length of the column. Removable base (TSC1000) or mounting legs (TSC1000H) allow for a range of custom mounting configurations.

Features:

- **Inline hand wheel operation**
Precision Acme screw and nut provide smooth operation over the entire 1,000 lbF range. Inline force minimizes column bending during testing.
- **Modular design**
Adjustable components accommodate a wide range of testing configurations.
- **Optional 6" [152 mm] digital travel display (TSC001)**
Useful in spring testing, rubber and polymer testing, and more.



TSC1000H



Model TSF / TSFH

Force, Manual, 1,000 lbF / 5,000 N

The TSF is a rugged stand with a rigid column, making it perfect for spring testing, high force tensile testing, and other applications. Precision side-mounted hand wheel operation is virtually effortless over the entire 1,000 lbF range, without back driving. Modular design allows for the gauge mounting plate and housing to be moved along the length of the column. Removable base (TSF) or mounting legs (TSFH) allow for a range of custom mounting configurations.

Features:

■ Side-mounted hand wheel operation

Ergonomic loading method reduces operator fatigue.

■ Exceptionally strong column

Rugged 3" x 3" column is durable and stiff, ideal for spring testing. Force is produced in line with the screw actuator, minimizing column deflection.

■ Optional 6" [152 mm] digital travel display (TSF001)

Useful in spring testing, rubber and polymer testing, and other applications.



TSF



TSFH

Specifications - Manual Force Test Stands

Model No.	Capacity lbF [N]	Maximum travel ¹ in [mm]	Loading method	Travel rate in [mm]	Daylight ² in [mm]
ES05	30 [150]	1.5 [38]	Spring-loaded lever	-	8 [203]
ES10	100 [500]	9 [229]	Lever	1.050 [26.7] / lever rev.	9 [229]
ES20			Top-mounted hand wheel	0.083 [2.1] / wheel rev.	
ES30	200 [1,000]	13 [330]	Side-mounted hand wheel	0.050 [1.3] / wheel rev.	14 [356] ³
TSA750	750 [3,750]	with travel stops: 2.75 [70] without travel stops: 6 [152]	Rack & pinion, lever can be positioned in 30° increments	3.00 [76.2] / lever rev.	10.5 [267] ³
TSA750H					14.5 [368] ³
TSB100	100 [500]				21 [533] ³
TSC1000	1,000 [5,000]	3.5 [89]	Inline hand wheel	0.10 [2.5] / wheel rev.	10 [254] ³
TSC1000H					13 [330] ³
TSF		4 [102]	Side-mounted hand wheel	0.013 [0.34] / wheel rev.	14 [356] ³
TSFH					16.5 [419] ³

1. Maximum travel depends on the grips or fixtures used during testing. The dimensions indicate distances without the use of grips or fixtures.
2. The clearance between the bottom of a mounted force gauge or sensor and the loading surface of the stand. Daylight will be reduced through the use of grips or fixtures. If the test sample size is close to the daylight specification above (or daylight less grip(s) or fixture(s)), a column extension may be necessary.
3. Column extensions are available.

Series F Force Testers

Series F Tension / Compression Test Frames are engineered for force testing applications up to 1,500 lbF (6.7 kN). Select from a broad range of force sensor capacities and an expansive array of grips and fixtures.

Series F is offered with two controller options. EasyMESUR® testers are basic and configurable for everyday testing needs. IntelliMESUR® systems address more complex, multi-step applications demanding more customization, greater selection of results, and advanced analytical tools.

 EasyMESUR®

 IntelliMESUR®



www.mark-10.com/seriesf

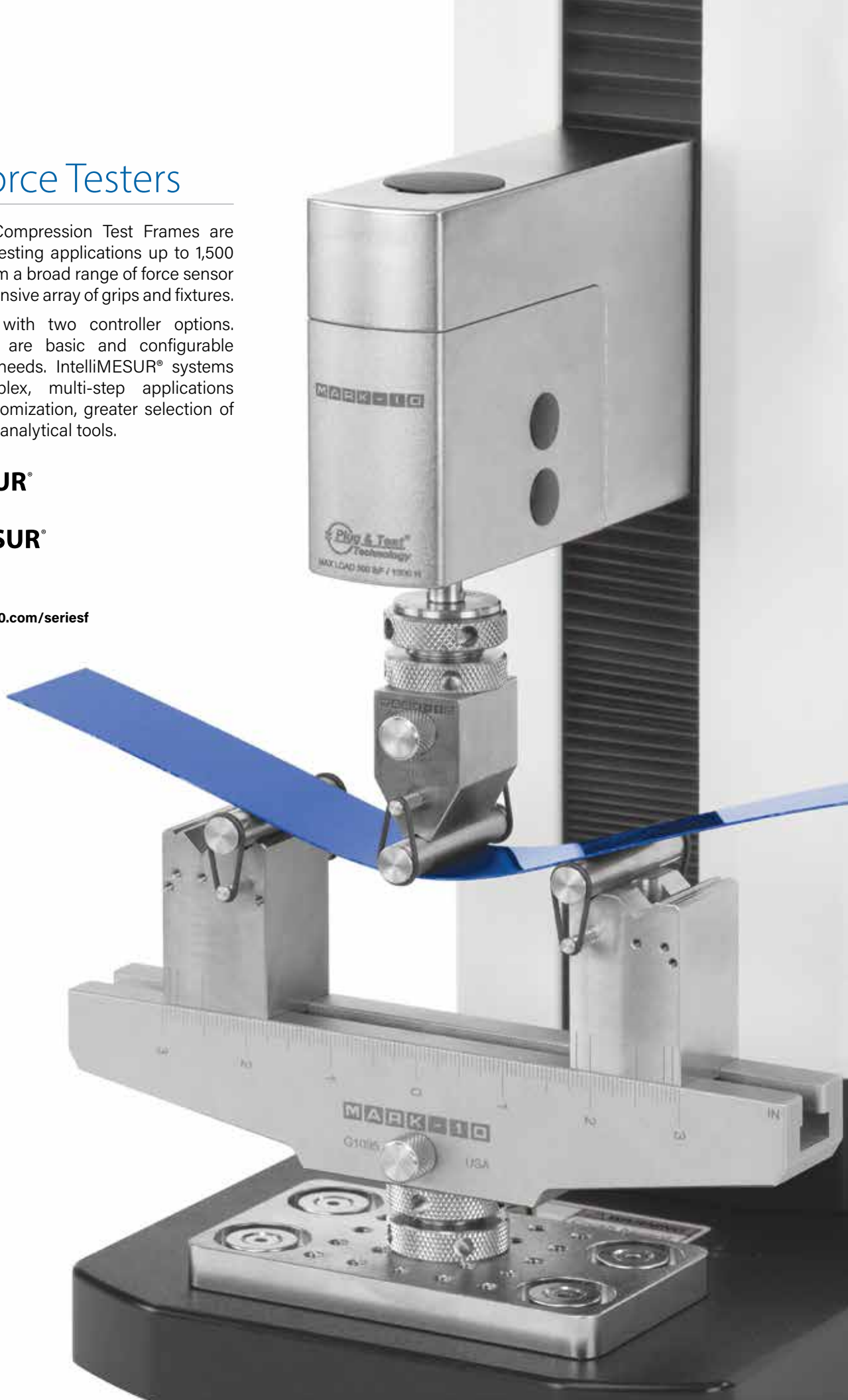



Meet the frames

There's a Series F test frame for every need and budget. Select from a wide range of force capacities, heights, and form factors.



F105 / F305 / F505

F755 / F1505

F755S / F1505S

F505H

	F105	F305	F505	F505H	F755	F755S	F1505	F1505S
Force capacity:	100 lbF [0.5 kN]	300 lbF [1.3 kN]	500 lbF [2.2 kN]	500 lbF [2.2 kN]	750 lbF [3.4 kN]	750 lbF [3.4 kN]	1,500 lbF [6.7 kN]	1,500 lbF [6.7 kN]
Travel distance:	18.0 in [457 mm]	18.0 in [457 mm]	18.0 in [457 mm]	18.0 in [457 mm]	32.0 in [813 mm]	14.2 in [360 mm]	32.0 in [813 mm]	14.2 in [360 mm]

Engineered for performance

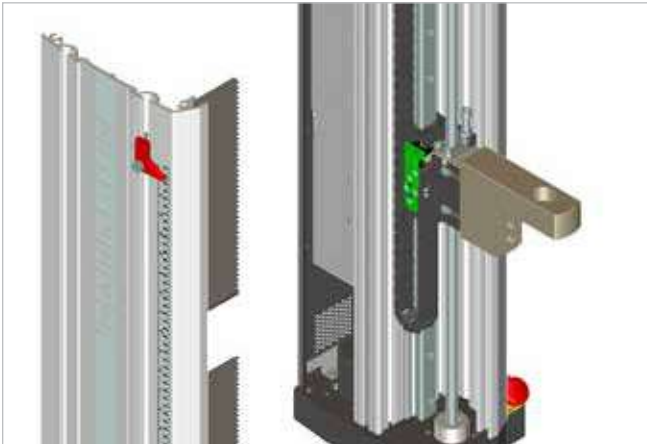

Rigid and precise mechanical design

Exceptionally rigid extrusion-based frames are engineered for stiffness. Factory compensation of test frames and force sensors ensure **position accuracy of up to ± 0.002 in / 0.05 mm under any load, at any position.**

Stepper motors and controllers drive a ballscrew and linear guideway for smooth, quiet operation, with virtually no speed variation under load.



Seamless force sensor interface

Ideal for most applications, Series FS05 smart force sensors mount directly to the crosshead of models F105, F305, F505, and F505H, without any connecting cables. Ranges available from 0.12 to 500 lbf [0.5 N to 2.5 kN]. Accurate to $\pm 0.1\%$ of full scale.



Modular design

Frame bases can be removed to accommodate column extensions and alternative mounting configurations. Most electronics are housed in a self-contained enclosure, easily accessed and replaced if needed.



Limit switches

Solid-state upper and lower limit switches may be used as test limits or as test exceptions. Dual-graduated rulers aid in switch placement.



EasyMESUR®

The EasyMESUR® integrated control panel centralizes test setup, test frame control, and data collection into one convenient place. Use the 7" [177 mm] touchscreen to create and run a wide range of tests, including:

- Test to a load
- Test to a sample break
- Test to a distance
- Load holding
- Cycle testing
- Average load testing
- Coefficient of friction testing
- Spring rate measurement

View data in graphical format or results tables. Save or export data as needed, or generate a report.

Key features

What's your point of view?

Run a test from any of the following views:

Standard view

View load and distance values with clear, simple controls.



Graph view

View a graph of load vs. distance or time, with pass/fail status.



Results view

View results for each run, with corresponding statistics for the results.



Secure user access

Control user access to sensitive areas, such as test editing and calibration, via password.

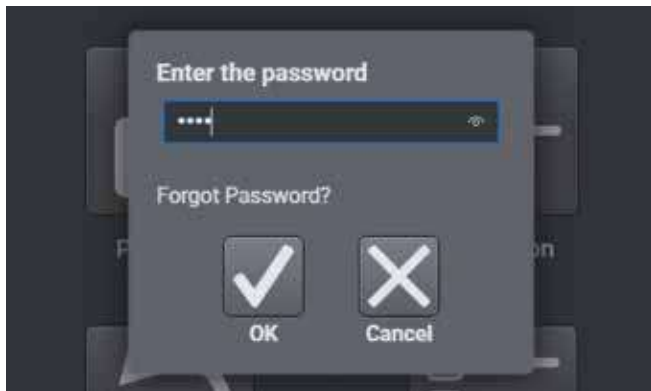

Easy test access

Open and edit tests saved within the control panel or external USB drive.





Control panel features



← Rugged aluminum housing

← 7" touch display

← USB-C port for connection to a PC

Import and export results, reports, and test files to a PC.

← USB-C port for an external flash drive

Import and export results, reports, and test files to a USB flash drive.



Intelligent manual control

Manually control the test frame to obtain quick load and distance results, or position the crosshead prior to a test. Select from several actuation methods, including momentary (button-hold), maintained (button release) motion, jog mode with three incremental distance presets.

With Mark-10's innovative **FollowMe®** function, push and pull on the force sensor to move the crosshead. Apply greater force to achieve faster motion. FollowMe® is responsive enough for quick positioning as well as fine adjustments.



FollowMe®



Manual Control view

Test setup is easy as 1-2-3

Select a test type, and EasyMESUR® will guide you through the setup.



Load Limit



Distance Limit



Break Limit



Load Hold



Cycle



Averaging

1. Basic Test Settings

- Test direction
- Speed
- Test-specific parameters
- Data storage preferences

2. Results Settings

- Select results
- Configure pass/fail limits
- Set data collection rate
- Set auto-return to home

3. Graph Settings

- Single-point or continuous graphing
- Select load vs. time or vs. distance
- Graphing start threshold

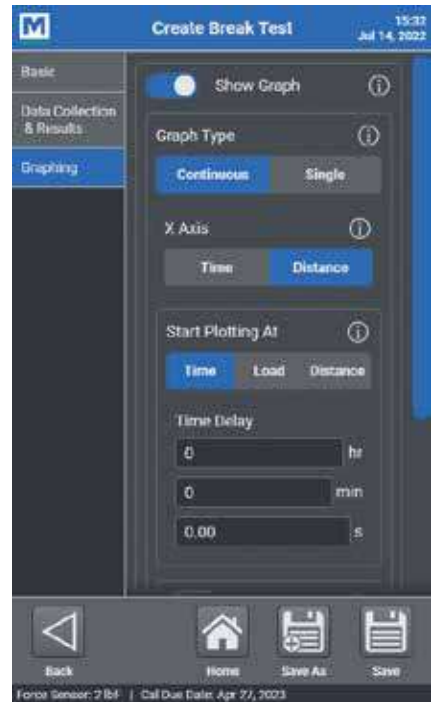
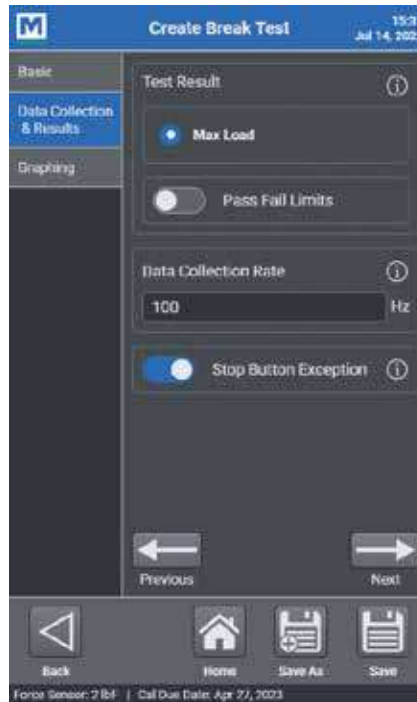
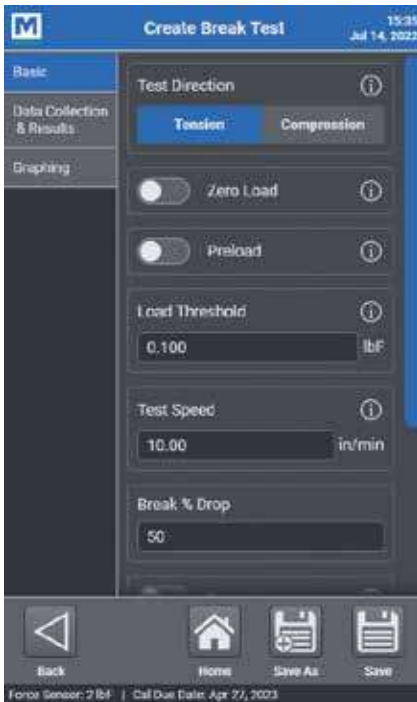



Robust data acquisition and management

Blazingly fast

Force sensor sampling rate of **5,000 Hz** yields accurate peak measurements even in quick-duration events. EasyMESUR® collects load and travel data at up to **100 Hz**, and saves up to **100,000** data points per run.

Customizable reporting

Create a PDF report, including results, statistics, graph, system and user information, and comments. Create report templates to save with future reports.

Save, export, and recall data

Save individual run data or results files to a USB drive or internal storage accessible from a PC.

Data and results may also be exported as .csv files.

Third-Party communication

Connects the EasyMESUR® control panel to a PC for data collection by a third-party application such as SPC software. Data can be transmitted from the control panel via the Data button or requested from the application via serial commands. Optional UXU100 USB communication adapter required.

ABC Manufacturing Company
123 Industrial Drive
Anytown, NY 54321

Peel Test Sample Report

Peel Test - 1 in. Sample

1" wide samples are loaded into G1008 grips. Max load values are recorded for each sample.

System Information:
EasyMESUR Version: 1.00.00
Test Frame Model: F305
Test Frame Serial Number: 4144714
Test Frame Capacity: 300 lbf / 4800 ozF / 150 kgF / 1500 N / 1.5 kN
Test Frame Firmware Version: 1.09.09
Force Sensor Model: FS05-50
Force Sensor Serial Number: 4081158
Force Sensor Capacity: 50 lbf / 800 ozF / 25 kgF / 25000 gF / 250 N
Force Sensor Calibration Date: Dec 30, 2021
Force Sensor Calibration Due Date: Dec 30, 2022

Run Number	Data Context	Status	Max Load [lbf]
1	Load	Pass	6.68
2	Load	Pass	7.60
3	Load	Pass	7.16
4	Load	Fail	4.90
5	Load	Pass	7.04

Statistics

Maximum	Minimum	Mean	Standard Deviation	Variance	Area Under Curve
7.60	4.90	6.68	0.936	0.876	33.38

Graph

The tests were completed successfully.

PDF report

Run Num	Status	Max Load [lbf]
1	Pass	6.68
2	Pass	7.6
3	Pass	7.16
4	Fail	4.9

Results .csv output

Tailored to your needs and budget

From basic tests to more advanced needs, EasyMESUR®'s unique optional function platform allows you to select the functions that best suit your requirements.

Any functions not purchased at time of order can be easily enabled in the field via activation codes.

EasyMESUR® systems are shipped in Evaluation Mode, in which all functions are enabled for 160 hours of operation.



Optional Functions

Function	Description	Co-requirements
Distance Measurement	Measure distance, with the ability to zero the reading.	-
Distance Limits	Stop at user-defined upper and lower distance limits.	- Distance Measurement
Preload	Zero the travel position automatically at a user-defined preload value.	- Distance Measurement
High Speed Extension	Extend the high end of the speed range, dependent upon test frame model.	-
Low Speed Extension	Extend the low end of the speed range, dependent upon test frame model.	-
Cycling	Set up to 100,000 cycles, with user-defined upper and lower dwell times. Cycle between any combination of limit switches, travel limits, breaks, and load limits.	- If cycling to distance limits, add Distance Measurement and Distance Limits - If cycling to a break point, add Break Detection
Break Detection	Stop when a user-defined drop in load occurs.	-
Load Holding	Stop at, and maintain, a user-defined load for a specified period of time. For best performance, use a force sensor with a capacity as close as possible to the target load.	-
FollowMe®	Push and pull on the sensor's loading shaft to jog the crosshead up and down, ideal for manual positioning prior to a test. Speed increases with applied force.	-
Graphing & Reporting	Graph load vs. time or distance, view statistics, and generate a report, including graph, results, run data, and other information.	- If graphing load vs. distance, add Distance Measurement
PC Control	Control the test frame with your own application using a supplied library of motion control and data collection serial commands. While PC control is active, the control panel becomes a pendant, limited to basic, manual controls.	- AC1107 cable, test frame to PC
Coefficient of Friction Measurement	Measure static & dynamic coefficients of friction, with user-defined sled weight.	- G1086 coefficient of friction fixture (suggested)
Spring Rate Measurement	Measure spring rate, with user-defined start and stop data collection triggers.	- Distance Measurement - Suggested functions: Distance Limits Preload

Optional Function Packages

Related functions are combined into available packages. A complete options package is also offered.

Package	Included Functions
Distance Measurement Package	- Distance Measurement - Distance Limits - Preload
Speed Extension Package	- High Speed Extension - Low Speed Extension
Advanced Functionality Package	- Cycling - Break Detection - Load Holding - FollowMe®
Complete Options Package	- All functions



Uniquely serviceable

Calibrate force sensors on the test frame or off-site

Calibrate force sensors in one of two ways:

Test frame

EasyMESUR® provides an integrated utility, with an intuitive step-by-step wizard. Manual controls allow the technician to use the test frame to apply tension and compression forces.

Off-site

Conveniently remove the force sensors for off-site calibration with a Mark-10 Model M7I or M5I indicator.



FS05 force sensor connected to an M5I indicator via AC1083 adapter for off-site calibration



Field-upgradeable

Update the test frame's firmware and EasyMESUR® software in the field via a simple user interface. No need to schedule a service call or to ship hardware to the factory.



Easy-to-service electronics

Most electronics are housed in an integrated module, easily replaced without special tools or processes.



Removing the electronics module

In The Box



F105 / F305 / F505 / F505H

- Control panel with mounting hardware
- #10-32M medium hook
- 5/16-18M large hook
- #10-32F 2" diameter compression plate
- #10-32 F/F coupler
- Adapter, 5/16-18M to #10-32F
- Set screw, #10-32 x 3/4"
- Hex nut, #10-32 (2)
- Power cord
- Allen wrench set



F755 / F755S / F1505 / F1505S

- Control panel with mounting hardware
- Eye end kit for base
- Lock ring for eye end (2)
- Spanner wrench (2)
- Power cord
- Allen wrench set



Specifications

	F105-EM	F305-EM	F505-EM	F505H-EM	F755-EM	F755S-EM	F1505-EM	F1505S-EM
Load capacity*:	100 lbF [0.5 kN]	300 lbF [1.3 kN]	500 lbF [2.2 kN]		750 lbF [3.4 kN]		1,500 lbF [6.7 kN]	
Maximum travel:	18.0 in [457 mm]				32.0 in [813 mm]	14.2 in [360 mm]	32.0 in [813 mm]	14.2 in [360 mm]
Standard speed range:	0.5 - 13 in/min [13 - 330 mm/min]				0.5 - 24 in/min [10 - 600 mm/min]			
Optional speed range:	0.02 - 45 in/min [0.5 - 1,100 mm/min]				0.001 - 60 in/min [0.02 - 1,525 mm/min]		0.001 - 70 in/min [0.02 - 1,800 mm/min]	
Load accuracy (% of full scale):	Test frame: ±0.1% Force sensor: Series FS05: ±0.1% Series FS06: ±0.15% Series R07: ±0.15%							
Peak sampling rate:	5,000 Hz							
Data acquisition rate:	100 Hz							
Speed accuracy:	±0.2% of setting, virtually no variation with load							
Position accuracy:	±0.006 in [0.15 mm], at any load or position, factory-compensated							
Distance resolution:	0.001 in [0.02 mm]							
Limit switch repeatability:	±0.001 in [0.03 mm]							
Power:	Universal input 100-240 VAC, 50/60 Hz, 120W				Universal input 100-240 VAC, 50/60 Hz, 300W		Universal input 100-240 VAC, 50/60 Hz, 450W	
Fuse type:	2.5 A, 250V, 3AG, SLO BLO				4A, 3AG, SLO BLO			
Weight:	60 lb [27 kg]		70 lb [32 kg]		184 lb [83 kg]	149 lb [68 kg]	197 lb [89 kg]	157 lb [71 kg]
Shipping weight:	75 lb [34 kg]		85 lb [39 kg]		235 lb [107 kg]	195 lb [88 kg]	247 lb [112 kg]	205 lb [93 kg]
Environmental conditions:	Indoor use only, up to 6,500 ft [2,000 m] above sea level Environmental conditions: 40 - 95°F [5 - 35°C], to 80% relative humidity at 31°C, decreasing linearly to 50% relative humidity at 40°C, non condensing Mains supply voltage fluctuations up to ±10 % of the nominal voltage Transient overvoltages up to the levels of Overvoltage Category II Use in environments up to Pollution Degree 2							
Conformance:	CE, UKCA							
Warranty:	3 years [see individual statement for further details]							

* Load capacity is reduced at higher speeds, as follows:

- F305-EM: limited to 200 lbF [1 kN] above 24 in [610 mm]/min
- F505-EM / F505H-EM: limited to 300 lbF [1.3 kN] above 24 in [610 mm]/min
- F755-EM / F755S-EM: limited to 500 lbF [2.3 kN] above 35 in [900 mm]/min
- F1505-EM / F1505S-EM: limited to 1,000 lbF [4.5 kN] above 60 in [1,525 mm]/min

Ordering Information

Model No. ¹	Description
F105-EM	Test frame with EasyMESUR® control panel, vertical, 100 lbF / 0.5 kN
F305-EM	Test frame with EasyMESUR® control panel, vertical, 300 lbF / 1.3 kN
F505-EM	Test frame with EasyMESUR® control panel, vertical, 500 lbF / 2.2 kN
F505H-EM	Test frame with EasyMESUR® control panel, horizontal, 500 lbF / 2.2 kN
F755-EM	Test frame with EasyMESUR® control panel, vertical, 750 lbF / 3.4 kN
F755S-EM	Test frame with EasyMESUR® control panel, vertical, short, 750 lbF / 3.4 kN
F1505-EM	Test frame with EasyMESUR® control panel, vertical, 1,500 lbF / 6.7 kN
F1505S-EM	Test frame with EasyMESUR® control panel, vertical, short, 1,500 lbF / 6.7 kN
Optional Functions ²	
EMF001-1 / EMF001-2	Distance Measurement
EMF002-1 / EMF002-2	Distance Limits
EMF003-1 / EMF003-2	Preload
EMF004-1 / EMF004-2	High Speed Extension
EMF005-1 / EMF005-2	Low Speed Extension
EMF006-1 / EMF006-2	Cycling
EMF007-1 / EMF007-2	Break Detection
EMF008-1 / EMF008-2	Load Holding
EMF009-1 / EMF009-2	FollowMe®
EMF010-1 / EMF010-2	Graphing & Reporting
EMF011-1 / EMF011-2	PC Control
EMF012-1/EMF012-2	Coefficient of Friction (COF) Measurement
EMF013-1/EMF013-2	Spring Rate Measurement
Optional Function Packages ²	
EMP001-1 / EMP001-2	Distance Measurement Package
EMP002-1 / EMP002-2	Speed Extension Package
EMP003-1 / EMP003-2	Advanced Functionality Package
EMP-COMP-1 / EMP-COMP-2	Complete Options Package

1. All test frame models contain a universal power supply (80 - 240V) and power cord with 110V US prong style. Add suffix 'E' for 220V European prong, 'U' for 220V UK prong, or 'A' for 220V Australian prong. Ex: F505-EME.

2. Use suffix -1 for models F105/F305/F505/F505H -EM, and -2 for models F755/F755S/F1505/F1505S -EM



Model No.	Description
Optional Equipment	
CERT-DS	Certificate of calibration, distance and speed
AC1116	USB cable, control panel to PC
AC1107	USB cable, test frame to PC
AC1094-1	Single column extension, 6 in / 150 mm, F105 / F305 / F505
AC1094-2	Single column extension, 12 in / 300 mm, F105 / F305 / F505
AC1094-3	Single column extension, 24 in / 600 mm, F105 / F305 / F505
AC1094-4	Single column extension, 6 in / 150 mm, F505H
AC1094-5	Single column extension, 12 in / 300 mm, F505H
AC1094-6	Single column extension, 24 in / 600 mm, F505H
AC1095-1	Double column extension, 6 in / 150 mm, F105 / F305 / F505
AC1095-2	Double column extension, 12 in / 300 mm, F105 / F305 / F505
AC1095-3	Double column extension, 24 in / 600 mm, F105 / F305 / F505
AC1092-1	Shield, F755S / F1505S
AC1092-2	Shield, F755 / F1505
AC1083	Adapter, FS05 sensor / PTAF adapter, to Plug & Test® connector / F755, F755S, F1505, F1505S test frames, 10 in / 250 mm cable
AC1084	Extension cable, 24 in / 610 mm, Plug & Test®, male/female
PTAF	Adapter, Plug & Test®, customer-supplied force sensor to Series F test frames
UXU100	USB communication adapter
DC6000-M	IntelliMESUR® upgrade, tablet control panel assembly & test frame mounting arm
15-1019	IntelliMESUR® software, customer installation on a Windows device, additional seat/USB dongle



M IntelliMESUR®

IntelliMESUR® is an advanced, integrated force measurement system. Select a pre-loaded 10.1" tablet with mounting bracket or use your own Windows device. With IntelliMESUR®, you can create and run a wide range of basic and multi-step tests, including:

- Limit testing to a load, break, or distance
- Height measurement
- Load holding*
- Cycle testing
- Multi-step testing, utilizing any combination of motion control and data collection functions
- Coefficient of friction (COF) testing (optional)
- Spring rate measurement

Perform individual runs or batches, and view data in graphical format or results tables. Save or export data as needed, or generate a report.

* For best performance with the load holding function, we recommend using a force sensor with a capacity as close as possible to the target load.



Key Features

Ready. Set. Go.

Quickly access up to 10 favorite tests. Associate an image with each favorite for easy identification.

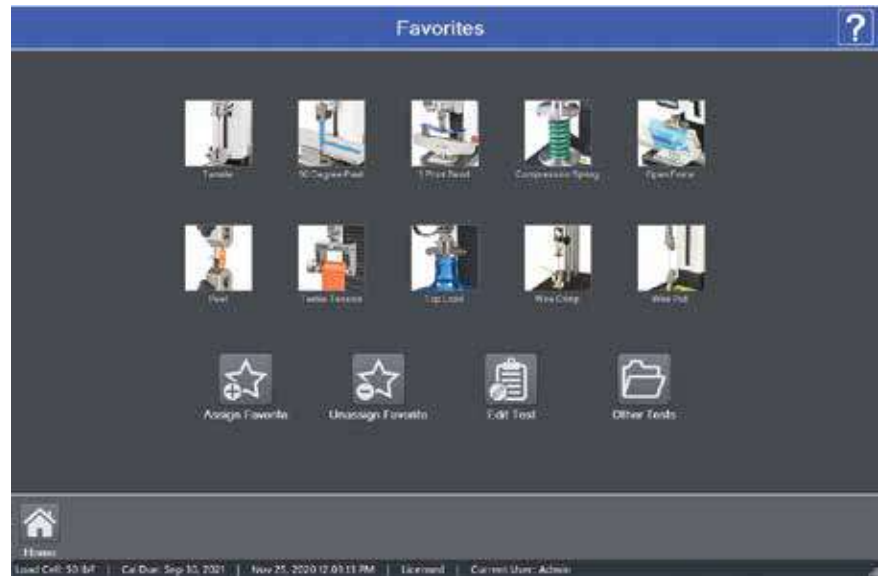

What's your point of view?

Run a test from the Graph or Results views, and switch views as needed. Pass / Fail indicator easily identifies problematic samples. Individual runs may be invalidated if, for example, the sample slips out of the grips, or the test was interrupted.

▶ Graph view

The Graph view plots load vs. distance or force vs. time. Overlay up to 10 runs for visual comparisons.



▶ Results view

The Results view displays user-selected results for each run. Statistics may be applied to selected results.

Run No.	Status	Serial Number	Date	Time	Speed (in/min)	Final Load (lbf)	Max Load (lbf)	Max Distance (in)
1	Pass	12345	Nov 25, 2020	12:02:02 PM	10.00	0.12	6.52	0.4640
2	Pass	45678	Nov 25, 2020	12:02:18 PM	10.00	0.16	6.51	0.4670
3	Pass	98765	Nov 25, 2020	12:02:33 PM	10.00	0.20	5.52	0.4810

Min						0.10	6.51	0.4670
Max						0.22	5.52	0.4610
Std. Dev						0.092	6.45	0.4785
Variance						0.0343	0.3348	0.0116
						0.1052	0.1121	0.0001

Multi-step tests

Building upon basic test wizards, easily incorporate any combination of steps, with the ability to loop a sequence of steps. Select from:

- Move to load
- Move to distance
- Move to break
- Hold a load or position
- Loop / cycle
- Datum
- Prompts
- Save current load or position
- Zero load or position
- Return to Home position



Insert and re-order steps as necessary

Operator prompting

Prompts can appear at the beginning of each test, batch, or run.

Ask prompts ask the operator for information which is saved in the results table - for example, a lot number. Type the response or use a barcode scanner.

Tell prompts provide instructions to the operator, and can include an image.



Ask Prompt



Tell Prompt

Take your measurements to new heights

Use **Height Mode** to determine height at a specific load, commonly used in spring testing. A datum may be set to define the reference point.



Deflection compensation

Series F test frames and force sensors are deflection-compensated at the factory, resulting in system distance measurement accuracy of **±0.002 in / 0.05 mm** at any load and at any position along the frame.

To further compensate grips and attachments, use IntelliMESUR®'s deflection compensation utility. The deflection offset file can be associated with the test setup file.





Test Setup

Basic tests

Select a test type, and IntelliMESUR® will guide you through the setup.



Load Limit



Distance Limit



Break Limit



Load Hold



Cycle

1. Pre-Test Settings

- Units of measurement
- Batch size
- Display preferences
- Preload
- Operator prompts

2. Test Settings

- Test objective
- Speed
- Pass / fail limits
- Exception limits

3. Results & Statistics Selection

- Final load
- Maximum load
- Minimum load
- Load at max. distance
- Load at min. distance
- Average load
- Delta load
- Maximum distance
- Final distance
- Minimum distance
- Height
- Distance at max. load
- Distance at min. load
- Distance at break
- Delta distance
- Area under the curve
- Spring rate

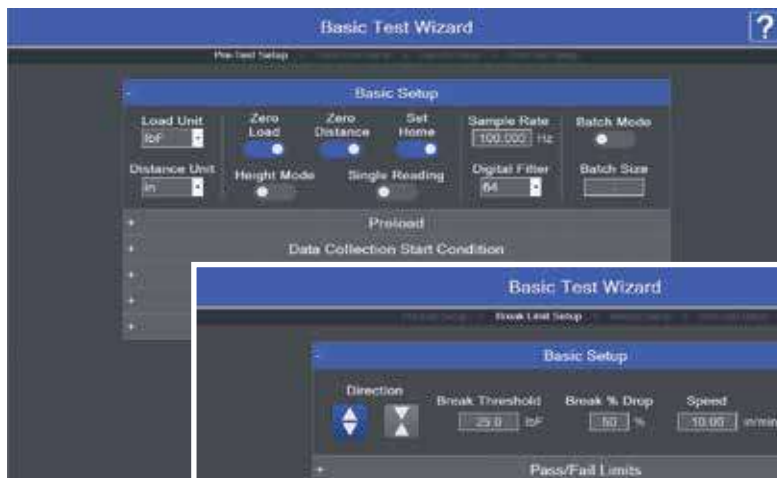

Pre-Test Settings

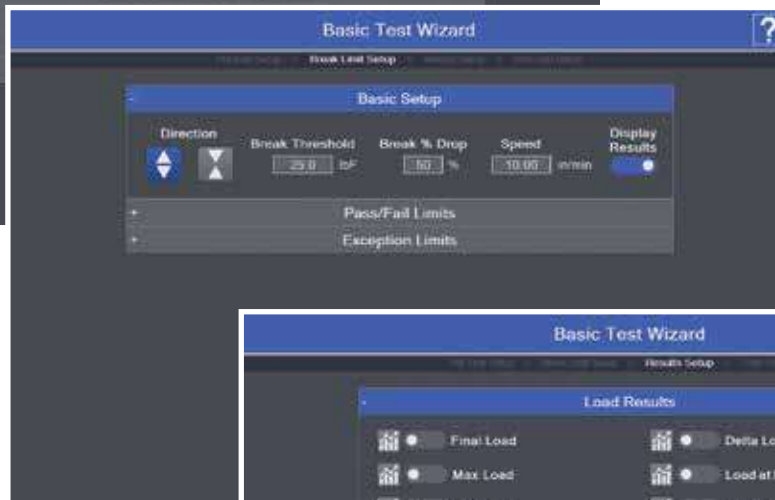

Test Settings



Results & Statistics Selection

Robust data acquisition and management

Blazingly fast

Force sensor sampling rate of **20,000 Hz** yields accurate peak measurements even in quick-duration events. IntelliMESUR® collects load and travel data at up to **1,000 Hz**, and allows up to **1 million data points** per run.

Customizable reporting

Print or create a PDF report, including results, statistics, graph, system and user information, and comments. Personalize the report with your company logo and an additional image.

Create report templates to save with future reports.

Save or export data

Automatically or manually save individual runs and results to a USB drive or file location of your choice. File names are automatically generated with the test name and time stamp, for quick searchability. Results sets and data from individual runs may also be exported as .csv files.

Component Break Test

System Information:

- IntelliMESUR Version: 1.0.0
- Test Frame Model: F305
- Test Frame Serial Number: 1234567
- Test Frame Capacity: 300 lbf / 1.5 kN
- Test Frame Firmware Version: 1.00.00
- Load Cell Model: RM105-0
- Load Cell Serial Number: 9876543
- Calibration Date: Sep 30, 2020
- Calibration Due Date: Sep 30, 2021

Run No.	Status	Serial Number	Date	Time	Speed (in/min)	Max Load (lbf)	Max Displacement (in)
1	Pass	12345	11-Dec-20	12:01:17 PM	10	4.75	0.3325
2	Pass	56789	11-Dec-20	12:01:40 PM	10	4.34	0.301
3	Pass	98765	11-Dec-20	12:01:58 PM	10	5.38	0.175

Statistics:

- Maximum: 5.60
- Minimum: 5.02
- Mean: 5.28
- Std. Dev: 0.2424
- Variance: 0.0588

Graph

All samples passed.

Results .csv output

MARK-10

Mark-10 Corporation
11 Dixon Ave.
Cocopaque, NY 11726 USA

Peel Test

Peel Test.txt

A batch of T-peel tests were performed on 1" samples, at a rate of 6 in/min. Peak results were obtained and compared against pass/fail criteria.

Equipment used:
- F305 test frame
- FS05-20 load cell
- G1006 grips

System Information:
IntelliMESUR Version: 1.0.0
Frame Model: F305
Test Frame Serial Number: 1234567
Test Frame Capacity: 300 lbf / 1.5 kN
Test Frame Firmware Version: 1.00.00
Load Cell Model: RM105-0
Load Cell Serial Number: 9876543
Calibration Date: Sep 30, 2020
Calibration Due Date: Sep 30, 2021

Run No.	Status	Date	Time	Speed (in/min)	Max Load (lbf)
1	Pass	Dec 22, 2020	04:22:45 PM	10.00	5.60
2	Pass	Dec 22, 2020	04:22:51 PM	10.00	5.20
3	Pass	Dec 22, 2020	04:22:57 PM	10.00	5.02

Statistics	Status	Date	Time	Speed (in/min)	Max Load (lbf)
Maximum					5.60
Minimum					5.02
Mean					5.28
Std. Dev					0.2424
Variance					0.0588

Graph

All samples passed.

PDF report



Intelligent manual control

Manually control the test frame to obtain quick force and distance results, or manually position the crosshead prior to a test. Select from several actuation methods, including momentary (button-hold), maintained (button release) motion, jog mode with three distance presets.

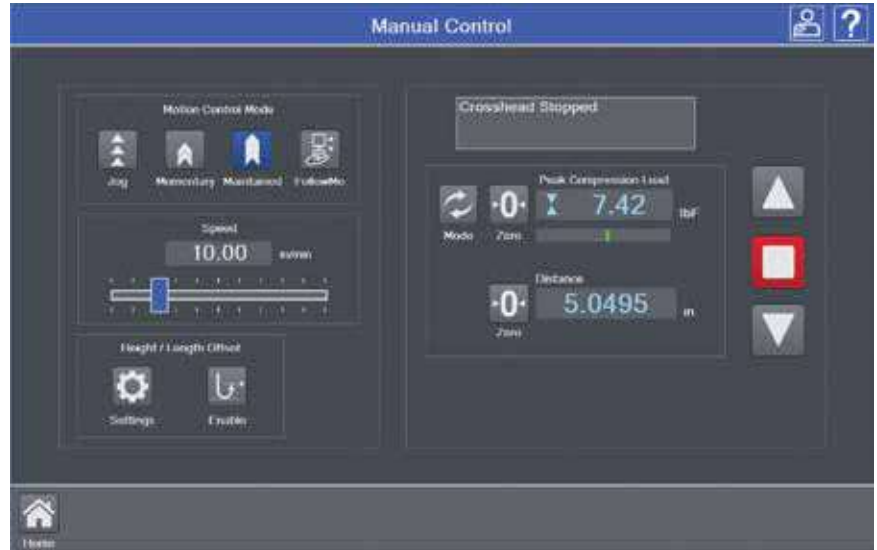

With Mark-10's innovative **FollowMe®** function, push and pull on the force sensor to move the crosshead. Apply greater force to achieve faster motion. FollowMe® is responsive enough for quick positioning as well as fine adjustments.



FollowMe®

The **Height / Length Offset** utility in Manual Control defines a reference point to accommodate applications in which grips cannot directly touch one another.



Uniquely serviceable

Calibrate force sensors on the test frame or off-site

Calibrate Series FS05, FS06 and R07 force sensors in one of two ways:

Test frame

IntelliMESUR® provides an integrated utility, with an intuitive step-by-step wizard. Manual controls allow the technician to use the test frame to apply tension and compression forces.

Off-site

Conveniently remove the force sensors for off-site calibration with a Mark-10 Model M7I or M5I indicator.



Field-upgradeable

Test frame firmware and IntelliMESUR® software can be updated in the field via a simple user interface. No need to schedule a service call or to ship hardware to the factory.



Easy-to-service electronics

Most electronics are housed in an integrated module, easily replaced without special tools or processes.



Removing the electronics module



FS05 force sensor connected to an M5I indicator via AC1083 adapter for off-site calibration



In The Box



F105 / F305 / F505 / F505H

- Control panel, mounting bracket, and hardware (-IMT models only)
- Mounting bracket, column end (F505H only)
- USB flash drive containing software installation files (-IM models only)
- USB dongle (-IM models only)
- USB cable
- #10-32M medium hook
- 5/16-18M large hook
- #10-32F 2" diameter compression plate
- #10-32 F/F coupler
- Adapter, 5/16-18M to #10-32F
- Set screw, #10-32 x 3/4"
- Hex nut, #10-32 (2)
- Power cord
- Allen wrench set



F755 / F755S / F1505 / F1505S

- Control panel, mounting bracket, and hardware (-IMT models only)
- USB flash drive containing software installation files (-IM models only)
- USB dongle (-IM models only)
- USB cable
- Eye end kit for base
- Lock ring for eye end (2)
- Spanner wrench (2)
- Power cord
- Allen wrench set

Specifications

	F105	F305	F505	F505H	F755	F755S	F1505	F1505S				
Load capacity*:	100 lbF [0.5 kN]	300 lbF [1.3 kN]	500 lbF [2.2 kN]		750 lbF [3.4 kN]		1,500 lbF [6.7 kN]					
Maximum travel:	18.0 in [457 mm]				32.0 in [813 mm]	14.2 in [360 mm]	32.0 in [813 mm]	14.2 in [360 mm]				
Speed range:	0.02 - 45 in/min [0.5 - 1,100 mm/min]				0.001 - 60 in/min [0.02 - 1,525 mm/min]		0.001 - 70 in/min [0.02 - 1,800 mm/min]					
Load accuracy (% of full scale):	Test frame: ±0.1% Force sensor: Series FS05: ±0.1% Series R06: ±0.15% Series R07: ±0.15%											
Peak sampling rate:	20,000 Hz											
Data acquisition rate:	1,000 Hz											
Speed accuracy:	±0.2% of setting, virtually no variation with load											
Distance accuracy:	±0.002 in [0.05 mm], at any load or position, factory-compensated											
Distance resolution:	0.0005 in / 0.01 mm											
Limit switch repeatability:	±0.001 in / 0.03 mm											
Power:	Universal input 100-240 VAC, 50/60 Hz, 120W				Universal input 100-240 VAC, 50/60 Hz, 300W		Universal input 100-240 VAC, 50/60 Hz, 450W					
Fuse type:	2.5A, 250V, 3AG, SLO BLO				4A, 3AG, SLO BLO							
Weight:	60 lb [27 kg]		70 lb [32 kg]		184 lb [83 kg]		149 lb [68 kg]		197 lb [89 kg]		157 lb [71 kg]	
Shipping weight:	75 lb [34 kg]		85 lb [39 kg]		235 lb [107 kg]		195 lb [88 kg]		247 lb [112 kg]		205 lb [93 kg]	
Environmental conditions:	Indoor use only Up to 6,500 ft [2,000 m] above sea level Temperature range: 40 - 95°F [5 - 35°C] Humidity range: up to 80% relative humidity at 31°C, decreasing linearly to 50% relative humidity at 40°C, non condensing Mains supply voltage fluctuations up to ±10 % of the nominal voltage Transient overvoltages up to the levels of Overvoltage Category II Use in environments up to Pollution Degree 2											
Conformance:	CE, UKCA											
Warranty:	3 years [see individual statement for further details]											

* Load capacity is reduced at higher speeds in the following models:

- F305: limited to 200 lbF [1 kN] above 24 in [610 mm]/min
- F505 / F505H: limited to 300 lbF [1.3 kN] above 24 in [610 mm]/min
- F755 / F755S: limited to 500 lbF [2.3 kN] above 35 in [900 mm]/min
- F1505 / F1505S: limited to 1,000 lbF [4.5 kN] above 60 in [1,525 mm]/min



Ordering Information

Model No.	Description
Test Frame + Pre-Configured Tablet Control Panel	
F105-IMT	Test frame with IntelliMESUR® pre-loaded tablet control panel, vertical, 100 lbF / 0.5 kN, 110V*
F305-IMT	Test frame with IntelliMESUR® pre-loaded tablet control panel, vertical, 300 lbF / 1.3 kN, 110V*
F505-IMT	Test frame with IntelliMESUR® pre-loaded tablet control panel, vertical, 500 lbF / 2.2 kN, 110V*
F505H-IMT	Test frame with IntelliMESUR® pre-loaded tablet control panel, horizontal, 500 lbF / 2.2 kN, 110V*
F755-IMT	Test frame with IntelliMESUR® pre-loaded tablet control panel, vertical, 750 lbF / 3.4 kN, 110V*
F755S-IMT	Test frame with IntelliMESUR® pre-loaded tablet control panel, vertical, short, 750 lbF / 3.4 kN, 110V*
F1505-IMT	Test frame with IntelliMESUR® pre-loaded tablet control panel, vertical, 1,500 lbF / 6.7 kN, 110V*
F1505S-IMT	Test frame with IntelliMESUR® pre-loaded tablet control panel, vertical, short, 1,500 lbF / 6.7 kN, 110V*
Test Frame + Standalone Software (for customer installation on a Windows device)	
F105-IM	Test frame with IntelliMESUR® software, single license, vertical, 100 lbF / 0.5 kN, 110V*
F305-IM	Test frame with IntelliMESUR® software, single license, vertical, 300 lbF / 1.3 kN, 110V*
F505-IM	Test frame with IntelliMESUR® software, single license, vertical, 500 lbF / 2.2 kN, 110V*
F505H-IM	Test frame with IntelliMESUR® software, single license, horizontal, 500 lbF / 2.2 kN, 110V*
F755-IM	Test frame with IntelliMESUR® software, single license, vertical, 750 lbF / 3.4 kN, 110V*
F755S-IM	Test frame with IntelliMESUR® software, single license, vertical, short, 750 lbF / 3.4 kN, 110V*
F1505-IM	Test frame with IntelliMESUR® software, single license, vertical, 1,500 lbF / 6.7 kN, 110V*
F1505S-IM	Test frame with IntelliMESUR® software, single license, vertical, short, 1,500 lbF / 6.7 kN, 110V*

* All test frame models contain a universal power supply (80 - 240V) and power cord with US prong style. Add suffix 'E' for European prong, 'U' for UK prong, or 'A' for Australian prong. Ex: F505-IMTE.



Model No.	Description
Optional Equipment	
IMF001	COF testing module for IntelliMESUR®
CERT-DS	Certificate of calibration, distance and speed
AC1094-1	Single column extension, 6 in / 150 mm, F105 / F305 / F505
AC1094-2	Single column extension, 12 in / 300 mm, F105 / F305 / F505
AC1094-3	Single column extension, 24 in / 600 mm, F105 / F305 / F505
AC1094-4	Single column extension, 6 in / 150 mm, F505H
AC1094-5	Single column extension, 12 in / 300 mm, F505H
AC1094-6	Single column extension, 24 in / 600 mm, F505H
AC1095-1	Double column extension, 6 in / 150 mm, F105 / F305 / F505
AC1095-2	Double column extension, 12 in / 300 mm, F105 / F305 / F505
AC1095-3	Double column extension, 24 in / 600 mm, F105 / F305 / F505
AC1092-1	Shield, 51.9" height
AC1092-2	Shield, 34.4" height
AC1085	Control panel tabeltop mounting kit
AC1093	USB hub
AC1083	Adapter, FS05 sensor / PTAF adapter, to Plug & Test® connector / F755, F755S, F1505, F1505S test frames, 10 in / 250 mm cable
AC1084	Extension cable for AC1083, 24 in / 610 mm, Plug & Test®, male/female
PTAF	Adapter, Plug & Test®, customer-supplied force sensor to Series F test frames
15-1019	IntelliMESUR® software, customer installation on a Windows device, additional seat
DC5000	EasyMESUR® control panel, with test frame mounting hardware



IntelliMESUR® / EasyMESUR® Comparison Chart

✓ = included ○ = optional ✗ = not available

Feature / Specification	IntelliMESUR®	EasyMESUR®
Basic test wizards	✓	✓
Multi-step tests	✓	✗
Extended speed ranges	✓	○
Distance measurement, distance limits, and preload	✓	○
Auto-return and cycling	✓	○
Break detection	✓	○
Load holding	✓	○
FollowMe® crosshead positioning	✓	○
Batch testing	✓	✗
Operator prompting	✓	✗
Pass / fail limits	✓	✓
Report creator	✓	○
Results	Large selection	1 per test
Graphing and statistics	✓	○
Overlay previous runs on graph	✓	✗
PC control via third-party application	✗	○
Coefficient of friction (COF) measurement	○	✗
Overload protection	✓	✓
Accuracy - force sensor	±0.1% or ±0.15% of sensor full scale	
Accuracy - test frame	±0.1% of sensor full scale	
Distance resolution	0.0005 in [0.01 mm]	0.001 in [0.02 mm]
System deflection compensation	✓	✓
Accuracy - distance	±0.002 in [0.05 mm], at any load or position	±0.006 in [0.15 mm], at any load or position
Accuracy - speed	0.2% of setting	
Peak load capture rate	20,000 Hz	5,000 Hz
Data acquisition rate	1,000 Hz	100 Hz
Number of data points per run	1,000,000	100,000
Users and permissions	3 permission tiers, unlimited users	1 tier (password access)
Runs on	Windows tablet or PC	Control panel only



TSTM-DC

Series TSTM-DC / TSTMH-DC

Torque, Motorized, 200 lbFin / 22 Nm

Series TSTM-DC advanced motorized torque test stands are designed for a wide variety of applications, including closure torque testing, fastener torque testing, and more. Two torque capacities are available, 100 lbFin (11.5 Nm) and 200 lbFin (22 Nm).

The stands include a torque loading plate with tapped holes for grip and fixture mounting. Stepper motor design eliminates speed variation with load. A lever-operated slider with travel stops makes engaging and disengaging samples quick and efficient. A modular mechanical design allows the stand to be configured for a variety of applications.

The controller features an integrated angle display and output, programmable angle travel limits, PC control capability, programmable cycling, auto return, overload protection, password protection, and more.

Features

■ **Broad speed range**

Set the rotational speed from 0.01 to 60 RPM (0.05 - 360°/s).

■ **No speed variation with load**

Stepper motor control eliminates any speed variation, regardless of the torque produced.



◀ **Fixture mounting table with angle indicator**

Rotating torque plate includes a matrix of tapped holes for grip or fixture mounting.

■ **Integrated digital angle indicator**

Measures in degrees or revolutions, with RS-232 output. USB converter available.

■ **Cycle between angle or torque limits**

■ **PC control via 3rd party applications**

■ **Custom column lengths**



TSTMH-DC



Specifications

Maximum torque:	TSTM-DC / TSTMH-DC: 100 lbFin [11.5 Nm] TSTM-DC-1 / TSTMH-DC-1: 200 lbFin [22.0 Nm]
Speed range:	TSTM-DC / TSTMH-DC: 0.01 - 15 RPM [0.05 - 90°/s] TSTM-DC-2 / TSTMH-DC-2: 0.04 - 60 RPM [0.2 - 360°/s] *
Speed accuracy:	±0.2% of setting, ±0% variation with load
Rotational travel accuracy:	±0.7° [0.002 rev.]
Rotational travel resolution:	0.1° [0.01 rev.]
Rotational travel repeatability:	0.1° [0.0003 revolutions]
Throat:	4.10" [104 mm]
Manual adjustment:	12° / adjustment knob revolution
Maximum slider travel:	15.5" [394 mm]
Slider travel rate:	1.047" [26.6 mm] / lever revolution
Universal power supply:	80-250 VAC

* Maximum torque decreases proportionately with speed, as follows:

- Maximum torque at 30 RPM = 50 lbFin [5.6 Nm]

- Maximum torque at 60 RPM = 25 lbFin [2.8 Nm]

Ordering Information

Model No.	Description
TSTM-DC	Torque stand, motorized, vertical, 110 V*
TSTMH-DC	Torque stand, motorized, horizontal, 110V*
TSTM-DC-1	Torque stand, motorized, vertical, 200 lbFin, 110V *
TSTMH-DC-1	Torque stand, motorized, horizontal, 200 lbFin, 110V *
TSTM-DC-2	Torque stand, motorized, vertical, 60 RPM max, 100 lbFin, 110V *
TSTMH-DC-2	Torque stand, motorized, horizontal, 60 RPM max, 100 lbFin, 110V *
Additional Items To Consider	
AC1108	Multi-function cable, M7I/M5I indicator to test stand
AC1104	Serial cable, test stand to PC
RSU100	Communication adapter, RS-232 to USB
TSF002	Horizontal / wall mounting kit
AC1016	Mounting adapter, MR55-200 to test stand
SP-2736-12	Column extension, 12 in. / 305 mm
SP-2736-24	Column extension, 24 in. / 610 mm
SP-2736-42	Column extension, 42 in. / 1065 mm
SP-2496	Upgrade to 200 lbFin, factory retrofit
SP-2624	Upgrade to 60 RPM, factory retrofit



TST



TSTH

Model TST / TSTH

Torque, Manual, 100 lbFin / 11.3 Nm

These manually operated torque test stands are ideal for a wide variety of applications requiring up to 100 lbFin (11.3 Nm) of torque, including closure torque testing, fastener torque testing, and more. Smooth hand wheel operation ensures ease of use and a lever-operated slider with travel stops makes engaging and disengaging samples quick and efficient. The stand includes a torque loading plate with tapped holes for grip and custom fixture mounting and an angle dial indicator with 2° resolution and unlimited angular travel. Modular mechanical design allows the stand to be configured for a variety of applications.

Features:

■ **Lever operated slider**

For simply and quickly engaging and disengaging samples.



◀ **Fixture mounting table with angle indicator**

Rotating torque plate includes a matrix of tapped holes for grip or fixture mounting



◀ **Optional digital angle indicator (TST001)**

Useful in torsion spring testing, bottle cap testing, catheter testing, and other applications.



Specifications

Torque capacity:	100 lbFin [11.3 Nm]
Maximum angular travel:	No limit
Angular rate:	12° per hand wheel revolution
Angle indicator resolution:	2°
Maximum slider travel:	15.5 in [394 mm] (column extensions available)
Slider travel rate:	1.047 in [26.6 mm] / lever revolution
Weight (without optional equipment):	TST: 33 lb [15 kg] / TSTH: 27 lb [12.3 kg]
Warranty:	3 years (see individual statement for further details)

Ordering Information

Model No.	Description
TST	Torque test stand, vertical, lever-operated, 100 lbFin
TSTH	Torque test stand, horizontal, lever-operated, 100 lbFin
TST001	Digital angle display for TST/TSTH, 110V
TST001E	Digital angle display for TST/TSTH, 220V Euro
SP-2736-12	Column extension, 12 in. / 305 mm
SP-2736-24	Column extension, 24 in. / 610 mm
SP-2736-42	Column extension, 42 in. / 1065 mm

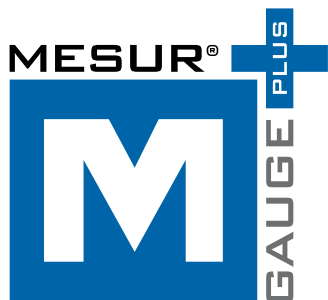

MESUR® gauge Plus Software

MESUR®gauge Plus expand the functionality of force and torque measuring instruments and test stands. Both programs share the ability to capture and display data in graphical format for load vs. time or load vs. travel vs. time. MESUR®gauge Plus adds the ability to control the motion of certain legacy Mark-10 Series ESM motorized test stands, coordinating motion control and data acquisition.

Free 90-day demo download available at mark-10.com/mesurgauge

Features:

- Tabulate and plot continuous or single-point data
- MESUR®gauge Plus starts and stops certain model motorized test stands, coordinating motion control and data collection with just one click
- Real time tabular and graphical data acquisition of load vs. time or load vs. travel vs. time
- Configurable start and stop test triggers (time, load, number of samples, or distance)
- Statistical calculations of acquired data. Automatically recalculates for custom ranges.
- One-click export to Excel
- Customize test setups for future recall
- Customize reports and templates
- Configure certain Mark-10 gauges and indicators through a simple interface
- View real time data on a large simulated instrument display

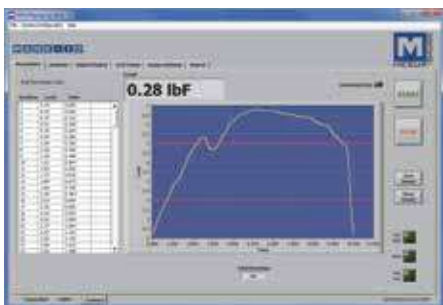

▲ View real time data in graphical and tabular formats. Also, remotely zero the force gauge or test stand travel display.

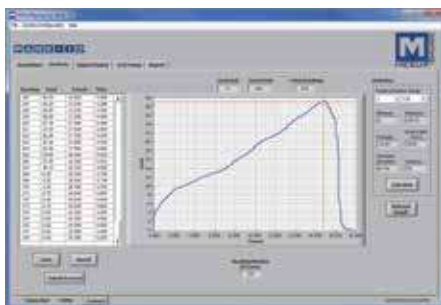

▲ Analyze test data via x-y cursor and statistical calculations for specified regions. Tests may be saved and recalled, and data may be exported to Excel with one click.



▲ Generate reports, including test data, graph, statistics, date and time, and user-configurable fields.



▲ Configure start and stop conditions, such as load, break, time, or distance. Select either discrete data point collection or continuous data collection at up to 50 Hz.

Ordering Information:

Model No.	Description
15-1005	MESUR®gauge Plus software*
15-1005-5	MESUR®gauge Plus software, 5 licenses*
15-1006	Upgrade, MESUR®gauge to MESUR®gauge Plus*

* Minimum required test stand controller firmware versions for motion control:

ESM303 / ESM303H: Front: 2.02.04, Main: 2.02.04

ESM1500: Front: 2.02.02, Main: 2.02.02



MESUR® Lite Software

MESUR® Lite is a basic data collection program for gauges, indicators, and testers. MESUR® Lite tabulates continuous or single point data from a gauge. Data saved in the gauge's memory can also be downloaded in bulk. One-click export to Excel allows for further data manipulation.

Free download from mark-10.com/mesurlite

Features:

- Tabulates continuous, single-point, or saved data from a gauge
- One-click export to Excel
- Configurable start and stop test triggers



◀ The Settings tab allows the user to select gauge series, COM port, reading mode (discrete or continuous data collection), and start and stop conditions.



◀ The Acquisition tab displays the current reading and tabulates data. Also provides a means of downloading saved data from a Mark-10 instrument and one-click export to Excel.

Software Comparison Chart

	MESUR®gauge	MESUR®gauge Plus	MESUR® Lite
Compatible equipment	Instruments, test stands, travel displays		Instruments only
Type of data	Load vs. time / load vs. travel / custom		Load vs. time only
Motion control of motorized stands	×	✓	×
Data tabulation		✓	✓
Export to Excel		✓	✓
Graphing and analysis tools		✓	×
Max. number of data points	Unlimited		5,000
Data sampling rate	0.000001 - 50/sec.		0.1 - 10/sec.
Statistical calculations		✓	×
Available start conditions	Time, load, travel distance		Load only
Available stop conditions	Time, load, sample break, travel distance, number of readings		Number of data points only
Configurable pass / fail limits		✓	×
Reporting	Yes, with customizable fields and templates		×
Save and recall test data		✓	×
Save and recall multiple test setups		✓	×
Gauge configuration utility		✓	×
Large digital display		✓	×

Grips & Attachments

Mark-10 grips and attachments are integral components of testing systems, designed for a wide range of tension, compression, and torque applications. Eye end adapters may be used with some gauges and sensors for quick-change convenience and compatibility with third party equipment.



www.mark-10.com/grips





All dimensions shown as in [mm]

Tensile / Pull

Wedge grips

Heavy-duty grips designed for a range of tensile testing requirements up to 2,000 lbf [10 kN]. Self-tightening stainless steel serrated or rubber jaw faces engage the sample through a spring loaded knob and rack and pinion type mechanism. The jaws ride on rollers, eliminating jamming common in conventional wedge grips.

Model No.	A	B	C	D	E	F	G
G1061-1			0.375 [9.5]	0.95 [24.1]	5/16-18 UNC		0.62 [15.7]
G1061	1.95 [49.5]	2.45 [62.2]	0.75 [19.1]	1.50 [38.1]	5/16-18 UNC	0 - 0.25 [0 - 6.4]	1.00 [25.4]
G1061-2			1.00 [25.4]	1.75 [44.5]	1/2-20 UNC		1.13 [28.7]
G1061-3						0 - 0.20 [0 - 5.1]	

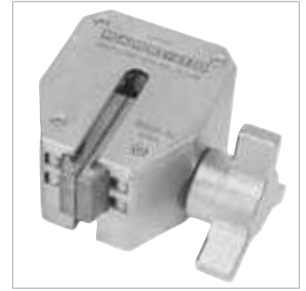
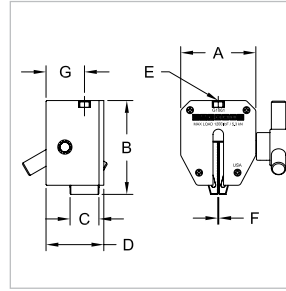

Model No.	Capacity lbf [N]	Weight lb [kg]	Jaw Material / Hardness	Included Adapters
G1061-1	200 [900]	0.50 [0.23]	416 SS / 55 RC	5/16-18M to #10-32F, #10-32 M/M stud*, 5/16-18 M/M stud*
G1061	1200 [5,300]	0.80 [0.36]		
G1061-2	2,000 [9,000]	0.90 [0.41]	Neoprene rubber Durometer = 70	1/2-20M to 5/16-18F, 1/2-20 M/M stud*, 5/16-18 stud*
G1061-3	50 [250]			

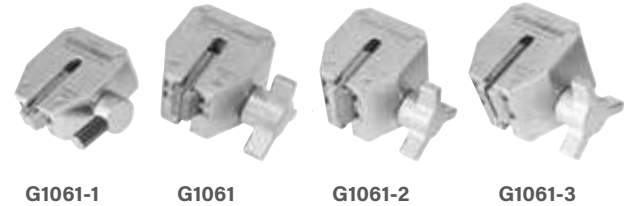

* Includes jam nuts

Miniature wedge grip

For general low force pull testing applications. The serrated, self tightening steel jaws are easily opened with a spring-loaded lever.

Model No.	A	B	C	D	E	F	G
G1062	1.37 [34.8]	2.49 [63.1]	0.19 [4.8]	0.32 [8.1]	#10-32 UNF	0 - 0.09 [0 - 2.3]	0.15 [3.9]

Model No.	Capacity lbf [N]	Weight lb [kg]
G1062	100 [500]	0.08 [0.04]

Includes a #10-32 M/M stud with jam nuts.

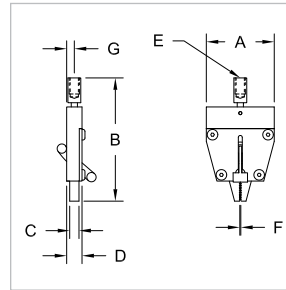

Ribbon wrap grip

Secures textile webbing, tape, and braided materials typically used in construction, shipping, and other industrial uses. Integrated eye end.

Model No.	Capacity lbf [kN]	Weight lb [kg]
G1111	2,000 [10]	5.2 [2.4]

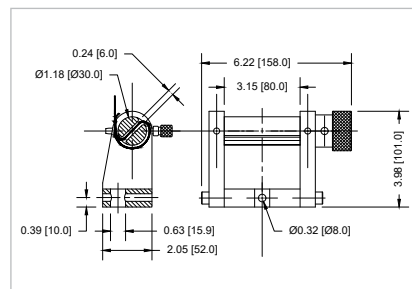



Miniature component grip

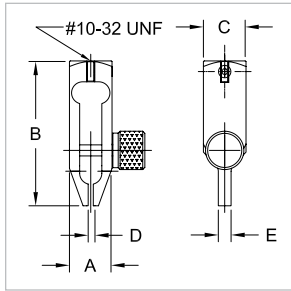

For testing small and hard-to-reach electronic and mechanical components. Slender profile allows this grip to be used in a wide range of applications.

Model No.	Capacity lbF [N]	Weight lb [kg]	A	B	C	D	E
G1003	30 [150]	0.05 [0.02]	0.5 [12.7]	1.7 [43.2]	0.5 [12.7]	0 - 0.07 [0 - 1.8]	0.15 [3.8]

Includes a #10-32 M/M stud with jam nuts.

Multi-jaw grip

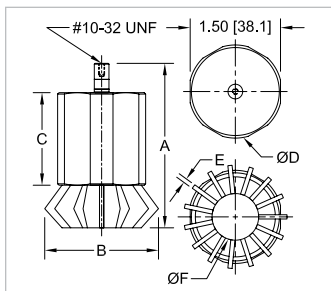

For gripping round or odd shaped items. Jaws expand and retract by rotating the housing.

Model No.	Capacity lbF [N]	Weight lb [kg]	ØA	B	C	ØD	E	ØF
G1056	100 [500]	0.30 [0.14]	3.50 [88.9]	2.30 [58.4] MAX	1.63 [41.4]	1.55 [39.4]	0.075 [1.91]	0.40 - 1.25 [10.2 - 31.7]

Includes a #10-32 M/M stud with jam nuts.

Clevis grip

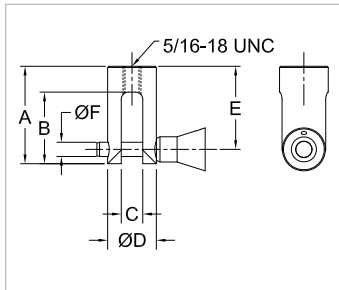

For ergonomic assessment, spring testing, and other pull testing applications.

Model No.	Capacity lbF [N]	Weight lb [kg]	A	B	C	D	E	ØF
G1077	500 [2,500]	0.29 [0.13]	1.70 [43.2]	1.25 [31.8]	0.38 [9.7]	0.85 [21.6]	1.45 [36.8]	0.25 [6.3]

Includes a 5/16-18M to #10-32F thread adapter, 5/16-18 M/M stud with jam nuts, and #10-32 M/M stud with jam nuts.

High capacity clevis grip

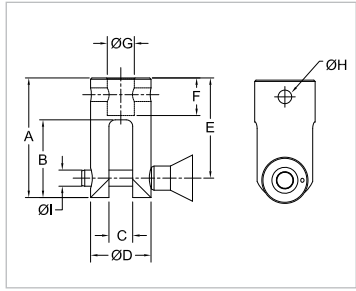

High capacity grip for spring testing and pulling testing applications. Integrated eye end.

Model No.	Capacity lbF [kN]	Weight lb [kg]
G1090	2,000 [9]	0.78 [0.35]

A	B	C	ØD	E	F	ØG	ØH	ØI
2.77 [70.4]	1.80 [45.7]	0.55 [14.0]	1.40 [35.6]	2.32 [58.9]	0.87 [22.1]	0.63 [15.9]	0.32 [8.0]	0.38 [9.7]



Packaging / Peel / Friction

Film and paper grips

For gripping film, paper, and other thin materials for tensile and peel testing. Adjustable serrated interlocking jaws grip the sample securely.

Model No.	Capacity lbF [N]	Weight lb [kg]	A	B	C	D
G1008	100 [500]	0.39 [0.18]	1.25 [31.8]	2.50 [63.5]	1.2 [30.5]	0 - 0.15 [0 - 3.8]
G1015-1		0.65 [0.29]	3.00 [76.2]			
G1015-2		0.80 [0.36]	5.00 [127.0]	3.00 [76.2]	1.90 [48.3]	0 - 0.50 [0 - 12.7]
G1015-3		0.90 [0.41]	7.00 [177.8]			
G1124	50 [250]	0.08 [0.04]	2.85 [72.4]	0.5 [12.7]	0.5 [12.7]	0 - 0.15 [0 - 3.8]

Includes a #10-32 M/M stud with jam nuts.

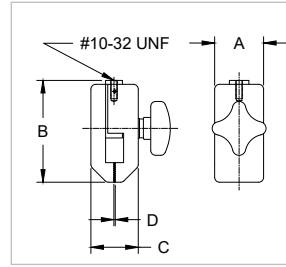

G1008

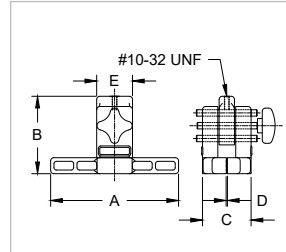

G1015-X

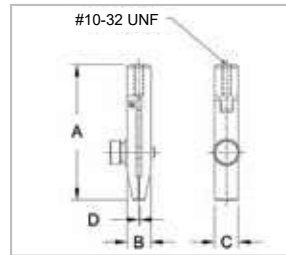

G1124

Pneumatic film and paper grip

Fully enclosed, air-powered grip for seal strength testing of packaging, elongation testing of various materials, and other tensile testing requirements. Serrated interlocking jaws effectively grip samples for up to 100 lbF of force. The grip features a unique integrated open/close valve for quick sample engagement and disengagement. An air connection kit, consisting of tubing and fittings needed to connect two grips, is available separately. A membrane repair kit is also available.

Model No.	Capacity	Weight lb [kg]	Max. pressure PSI (MPa)	Air input thread	A
G1046	100 lbF [500 N] at 100 PSI [0.86 MPa]	0.58 [0.26]	125 [0.86]	#10-32 UNF	0 - 0.13 [0 - 3.3]

Includes a #10-32 M/M stud with jam nuts, one spare rubber membrane*, one alcohol wipe, and two cotton swabs.

The optional air connection kit includes:

- Coiled tubing, 1/8" OD, 1/16" ID, 8" retracted length (qty. 2)
- Y-splitter (qty. 1)
- Straight tubing, 1/8" OD, 1/16" ID, 5' length (qty. 1)
- Elbow fitting, tubing termination (qty. 2)
- Elbow fitting, tubing to #10-32M (qty. 1)
- Thread adapter, #10-32F to 1/4" NPT M (qty. 1)
- Adhesive-backed guide (qty. 4)

Model No.	Description
AC1019	Air connection kit for G1046
AC1044*	Maintenance kit for G1046*

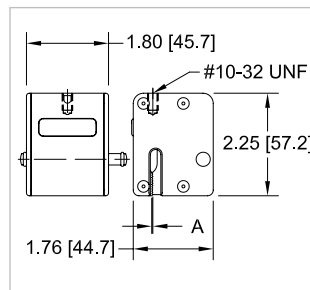

The optional maintenance kit* includes:

1. Rubber membrane (qty. 5)
2. Alcohol wipe (qty. 5)
3. Cotton swab (qty. 12)
4. Wrench set



* The flexible internal membrane actuating the movable jaw has a variable life expectancy dependent upon the maximum air pressure used and the quality of the compressed air. It should be free from impurities, solvents and oils. Since field conditions are outside of Mark-10's control, the standard 3-year warranty does not apply to the flexible membrane. For convenience, a spare membrane and alcohol wipe is included with every new grip.



90° peel fixture

For testing adhesive strength of tapes, films, and packaging. Maintains a 90° angle between the table and direction of pull. An integrated limit switch automatically stops the motion of most motorized test frames when the working table has reached its end of travel. Optional adjustable angle accessories allow for testing between 0° and 90°.

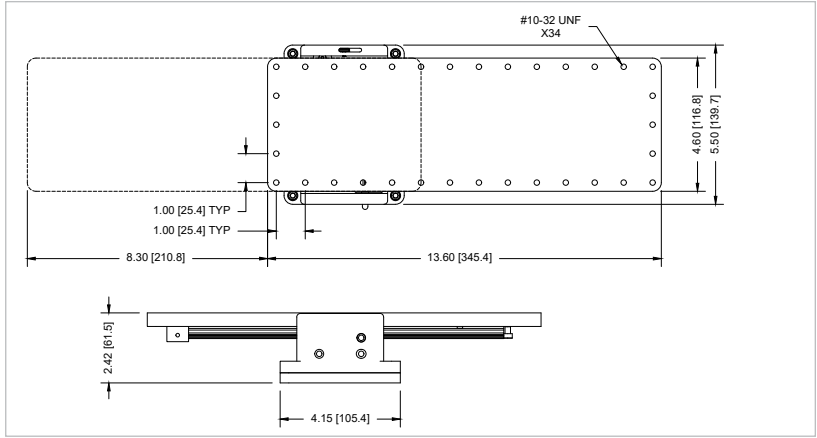

Model No.	Description	Capacity lbF [N]	Weight lb [kg]
G1109	90° peel fixture	100 [500]	6.0 [2.7]
AC1078	Adjustable angle pulley adapter, 0-90°	30 [150]	1.4 [0.6]
AC1079	Adjustable angle mount, ±30°	100 [500]	1.7 [0.8]
AC1080	Adapter, G1023 / G1058 grip to G1109	100 [500]	0.4 [0.2]
AC1087	Adapter, G1109	-	-



AC1078



AC1079



AC1080

G1109 is compatible with the following test stands and frames:

F105, F305, F505, F755*, F755S*, F1505*, F1505S*, ESM303, ESM750LC*, ESM750SLC*, ESM1500LC*, ESM1500SLC*

* AC1087 adapter required.

Coefficient of friction fixture

For determining friction properties of paper, film, and other thin flexible materials. Conforms to ASTM D1894 and other relevant standards. Includes work table, 200 g sled, cable, and low-friction pulley. Static and kinetic coefficients can be measured using the M5-2-COF gauge.

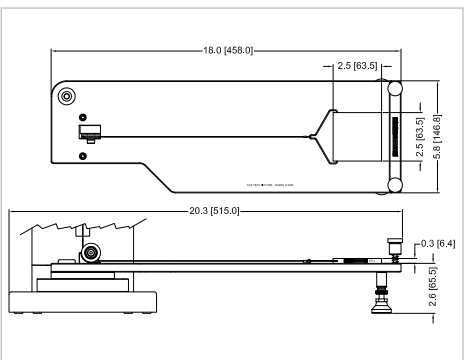

Model No.	Description
G1086	Coefficient of friction fixture
COF-K1	Kit - G1086 COF fixture + M5-2-COF force gauge
AC1076-1	Pair of mounting posts for F1505, F1505S, ESM750, and ESM750S (AC1055 mounting plate required for ESM750 / ESM750S)
AC1076-2	Pair of mounting posts for ESM1500 and ESM1500S (AC1055 mounting plate required)

Compatible with the following test frame models: F105, F305, F505, F755, F755S, ESM303.



Score bending fixture

Produces a 90° bend in fiber board materials and plastics to conform to TAPPI standard T829. Set of upper and lower dies.

Model No.	Capacity lbF [N]	Weight lb [kg]
G1071	50 [250]	Upper die: 0.15 [0.07] Lower die: 0.30 [0.14]

Upper die includes a 5/16-18M to #10-32F thread adapter and #10-32 M/M stud with jam nuts.

Mounts directly to the following test frames (motorized test frames recommended):

- F105, F305, F505, F755, and F1505 test frames.
- ESM303, ESM750, ESM1500, ES30, TSC1000, and TSF test stands.
- Also compatible with models ES10/ES20 test stands when ordered with optional AC1060 mounting plate.

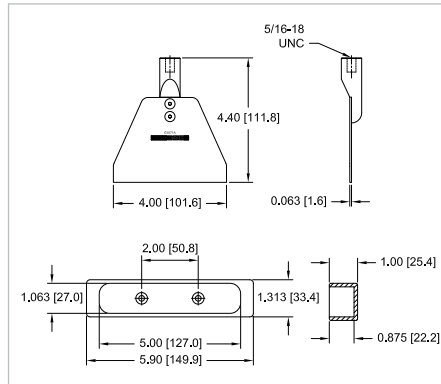

Opening force fixture

For determining the opening force of flat folded cartons along score lines. Set of upper and lower dies.

Model No.	Capacity lbF [N]	Weight lb [kg]
G1072	50 [250]	Upper die: 0.06 [0.03] Lower die: 0.10 [0.05]

A	B	C	D
0.75 [19.1]	1.00 [25.4]	0.50 [12.7]	0.25 [6.4]

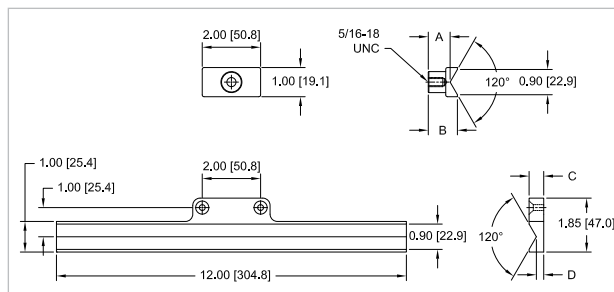

Upper die includes a 5/16-18M to #10-32F thread adapter and #10-32 M/M stud with jam nuts.

Mounts directly to the following test frames (motorized test frames recommended):

- F105, F305, F505, F755, and F1505 test frames.
- ESM303, ESM750, ESM1500, ES30, TSC1000, and TSF test stands.
- Also compatible with models ES10/ES20 test stands when ordered with optional AC1060 mounting plate.

Loop tack fixture

For tack force testing of pressure-sensitive adhesives, in conformance with ASTM D6195 and related standards. A looped sample is loaded onto the test strip, and the closed end of the loop is secured by an upper grip (not included - suggested model: G1008, pictured below). The test strip may be indexed in three positions, allowing for three tests to be performed between cleaning cycles.

Model No.	Capacity lbF [N]	Weight* lb [kg]	Test strip material
G1098	100 [500]	1.10 [0.5]	T304 SS, per ASTM A666

* Including one test strip.

Includes a 5/16-18 M/M stud with jam nuts.

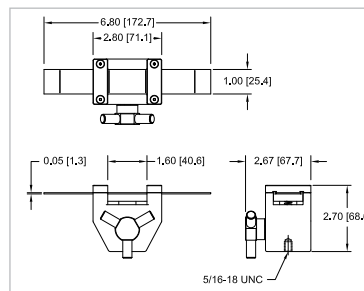



Flip cap pull grip

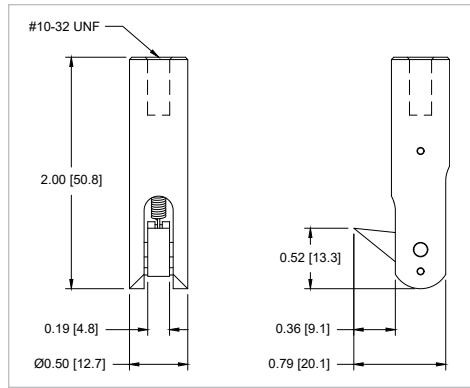

Engages the tab on a flip cap for pull-off force measurements. A spring-loaded hook retracts as it is lowered into the starting position, then snaps into place below the tab.

Model No.	Capacity lbF [N]	Weight lb [kg]
G1104	20 lbF [100 N]	0.10 lb [0.04 kg]

Includes a #10-32 M/M stud with jam nuts.

Cork pull fixture

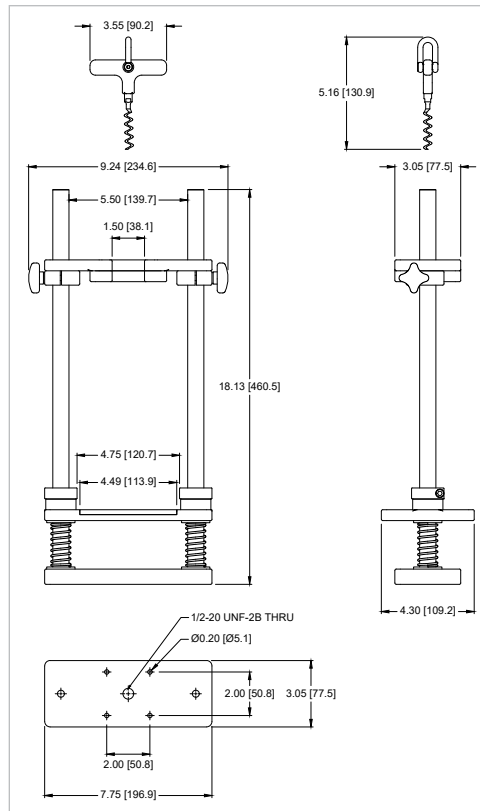

Extracts a cork stopper from a bottle for pull force measurements, in conformance with ISO 9727.

Model No.	Capacity lbF [N]	Weight lb [kg]
G1105	200 lbF [1000 N]	9.5 lb [4.3 kg]

Includes a G1035 large hook, G1018-2 swivel adapter, and test stand mounting hardware. Recommended for use with a motorized test frame.



Vise / Parallel Jaw

Parallel jaw / vise-action grip, small

For general tensile and pull testing applications.

Model No.	Capacity lbF [N]	Weight lb [kg]	A	B	C	D
G1013	200 [1,000]	0.65 [0.29]	1.75 [44.5]	2.25 [57.2]	1.25 [31.8]	0 - 0.25 [0 - 6.3]

Includes a 5/16-18M to #10-32F adapter and #10-32 M/M stud with jam nuts.

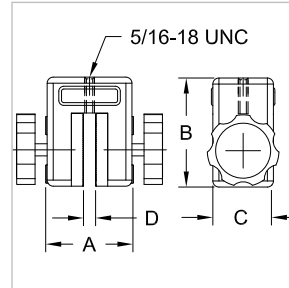

Parallel jaw / vise-action grip, medium

For general tensile and pull testing applications. Integrated eye end.

Model No.	Capacity lbF [N]	Weight lb [kg]	Housing Material	Jaw Material
G1101	200 [1,000]	1.0 [0.5]	Aluminum	Hardened steel, 58 RC

Extended length jaws are available: 1.97 in [50.0 mm], 3.15 in [80.0 mm], 3.94 in [100.0 mm]. See website for details.

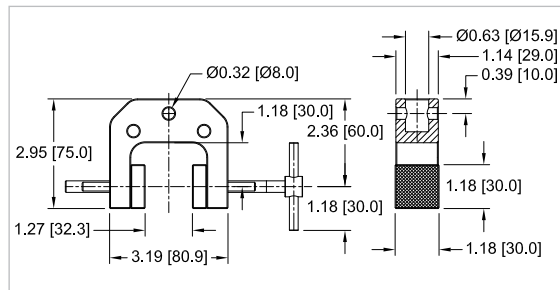

Parallel jaw / vise-action grip, large

For general tensile and pull testing applications. Includes an adjustable stop to ensure consistent sample placement. Integrated eye end.

Model No.	Capacity lbF [kN]	Weight lb [kg]	Housing Material	Jaw Material
G1100	2,000 [9]	5.9 [2.7]	Aluminum	Hardened steel, 58 RC

3.94 in [100.0 mm] extended length jaws are available. See website for details.

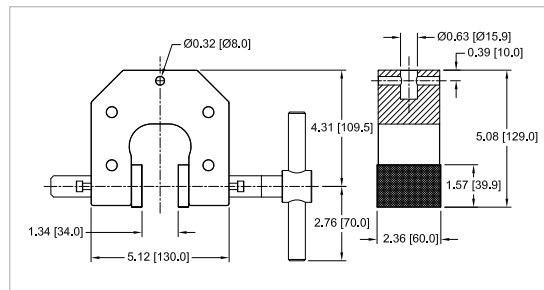



Vise grip, standard

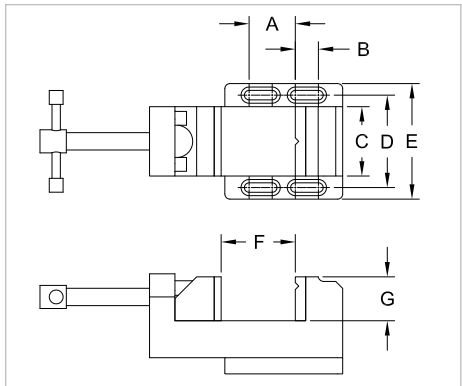

General purpose vise for a wide range of tension and compression testing applications.

Model No.	Capacity lbF [N]	Weight lb [kg]
G1074	500 [2,500]	2.0 [0.9]

A	B	C	D	E	F	G
1.00 [25.4]	0.50 [12.7]	1.50 [38.1]	2.00 [50.8]	2.50 [63.5]	0 - 1.50 [0 - 38.1]	1.00 [25.4]

- Mounts directly to the following test frames:
- F105, F305, F505, F755, and F1505.
 - ESM303, ESM750, ESM1500, ES30, TSC1000, and TSF.
 - Also compatible with models ES10/ES20 when ordered with optional AC1060 mounting plate. A motorized test stand is recommended.

Vise grip, self-centering

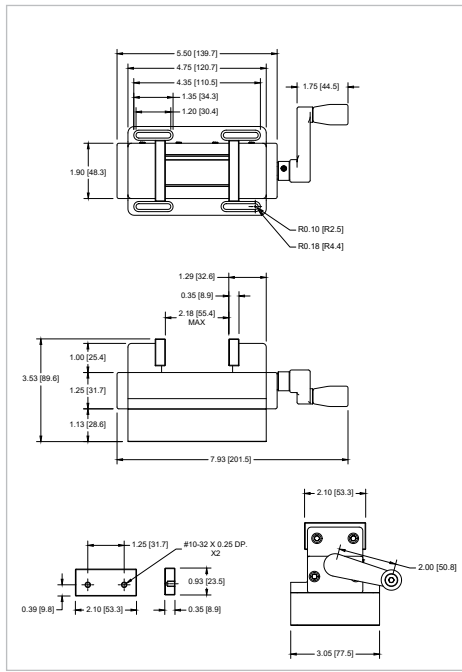

General purpose vise, for a wide range of tension and compression testing applications. Self-centering, replaceable jaws can be field-modified to improve sample gripping characteristics.

Model No.	Capacity lbF [N]	Weight lb [kg]
G1106	500 [2,500]	3.00 [1.36]

- Mounts directly to the following test frames (motorized test frames recommended):
- F105, F305, F505, F755, and F1505.
 - ESM303, ESM750, ESM1500, ES30, TSC1000, and TSF.
 - Also compatible with models ES10/ES20 test stands when ordered with optional AC1060 mounting plate.



Wire / Rope / Yarn / Tubing

Wire terminal grips

Secures wire terminals, cables, connectors, and other samples for pull testing.

Model No.	Capacity lbF [N]	Weight lb [kg]	ØA	B	C	D
G1001					0 - 0.125 [0 - 3.1]	
G1001-1	200 [1,000]	0.29 [0.13]	1.00 [25.4]	3.40 [86.4]	0.125 - 0.25 [3.1 - 6.3]	1.45 [36.8]
G1001-2					0.25 - 0.375 [6.3 - 9.5]	

Includes a 5/16-18M to #10-32F adapter and #10-32 M/M stud with jam nuts.

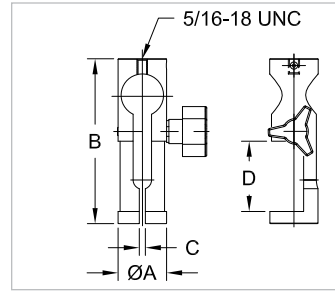

Wire terminal grip, turret style

Secures wire terminals, cables, connectors, and other samples for pull testing. Indexing wheel contains slots of varying widths to accommodate a wide range of sample shapes and sizes.

Model No.	Capacity lbF [N]	Slot Widths	Weight lb [kg]
G1076	500 [2,500]	0.03 [0.7], 0.04 [1.0], 0.06 [1.5], 0.08 [2.0], 0.09 [2.3], 0.11 [2.8], 0.12 [3.0], 0.14 [3.5], 0.15 [3.8], 0.17 [4.3], 0.18 [4.5], 0.20 [5.1], 0.21 [5.3], 0.23 [5.8], 0.25 [6.3]	1.00 [0.45]

Includes a 5/16-18M to #10-32F adapter and #10-32 M/M stud with jam nuts.

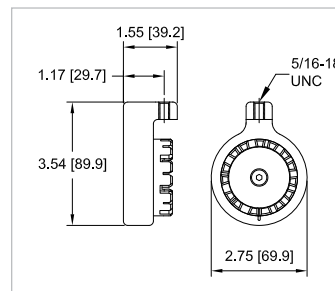

High capacity wire terminal grip

Secures wire terminals, cables, connectors, and other samples for pull testing. Indexing wheel contains slots of varying widths to accommodate a wide range of sample shapes and sizes. Integrated eye end.

Model No.	Capacity lbF [kN]	Slot Widths	Weight lb [kg]
G1093	2,000 [9]	0.08 [2.0], 0.12 [3.0], 0.16 [4.0], 0.20 [5.0], 0.24 [6.0], 0.31 [8.0], 0.39 [10.0], 0.46 [11.8]	6.4 [2.9]

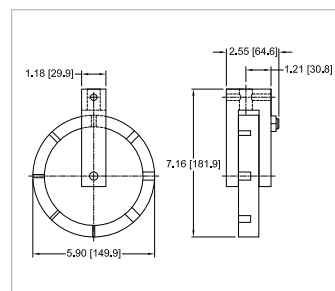



Dual roller grips

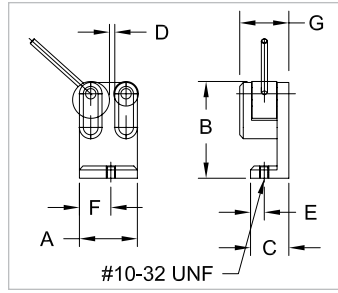

Secures the ends of wire, cable, and tubing samples for pull testing. Engaging and disengaging samples is quick and easy via an efficient cam design and convenient side slot for sample insertion. Serrated steel rollers produce effective gripping characteristics.

Model No.	Capacity lbF [N]	Weight lb [kg]	A	B	C	D	E	F	G
G1002	200 [1,000]	0.19 [0.09]	1.18 [30.0]	2.00 [50.8]	0.75 [19.1]	0 - 0.25 [0 - 6.3]	0.22 [5.6]	0.64 [16.5]	1.0 [25.4]

Includes a #10-32 M/M stud with jam nuts.

Adjustable dual roller grip

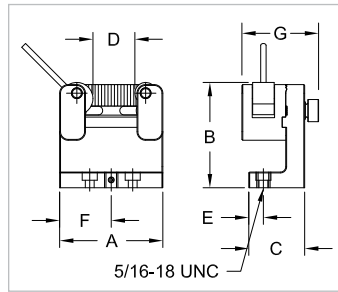

Secures tubing, cables, and odd shaped samples for pull testing applications. Engaging and disengaging samples is quick and easy, with a side slot for sample insertion and serrated steel rollers. Rollers can be repositioned as required for the application.

Model No.	Capacity lbF [N]	Weight lb [kg]	A	B	C	D	E	F	G
G1085	500 [2,500]	0.51 [0.23]	2.40 [61.0]	2.45 [62.2]	1.30 [33.0]	0 - 1.00 [0 - 25.4]	0.34 [8.6]	1.20 [30.5]	1.78 [45.3]

Includes a 5/16-18 M/M stud with jam nuts.

Miniature filament grip

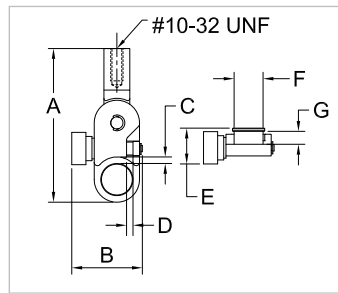

Secures small diameter wires and filaments. The sample wraps around the bollard and the loose end is secured by the adjustable jaw. Integrated swivel ensures sample alignment under load.

Model No.	Capacity lbF [N]	Weight lb [kg]	A	B	C	D	E	F	G
G1078	50 [250]	0.06 [0.03]	2.38 [60.4]	1.09 [27.7]	0.10 [2.5]	0.10 [2.5]	0.55 [14.1]	∅0.45 [11.4]	0.20 [5.1]

Includes #10-32 M/M stud with jam nuts.



Wire / rope grip, medium

Secures wire and rope. The sample wraps around the bollard and the loose end is secured by the adjustable rubber-faced jaw. Integrated eye end.

Model No.	Capacity lbF [N]	Weight lb [kg]
G1103	200 [1,000]	0.6 [0.6]

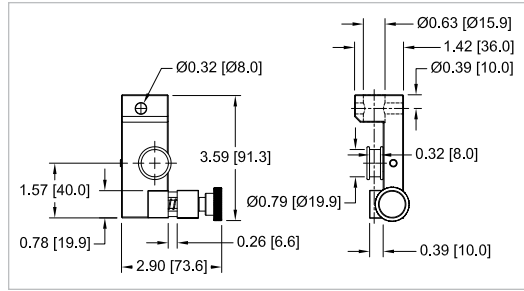

Wire / rope grip, large

Secures wire and rope. The sample wraps around the bollard and the loose end is secured by an adjustable jaw. Integrated eye end.

Model No.	Capacity lbF [N]	Weight lb [kg]
G1102	1,000 [5,000]	1.8 [0.8]

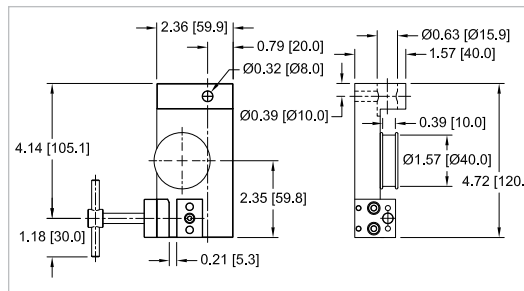

Wire / rope grip, high capacity

For high capacity wire and rope pull testing applications. Secures the free end of the sample via a bollard and vise. Integrated eye end.

Model No.	Capacity lbF [kN]	Weight lb [kg]
G1092	2,000 [9]	6.0 [2.7]

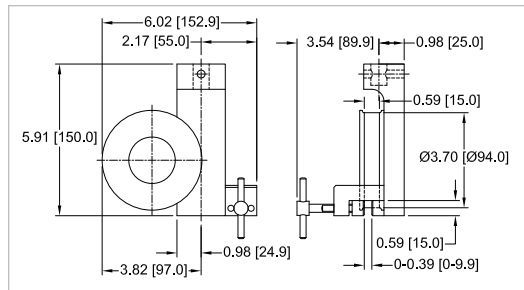

High capacity eccentric roller grip

Features a serrated cam for effectively securing wires, plastics, textiles, and other materials in pull testing applications. Integrated eye end.

Model No.	Capacity lbF [kN]	Weight lb [kg]
G1094	2,000 [9]	74 [3.4]

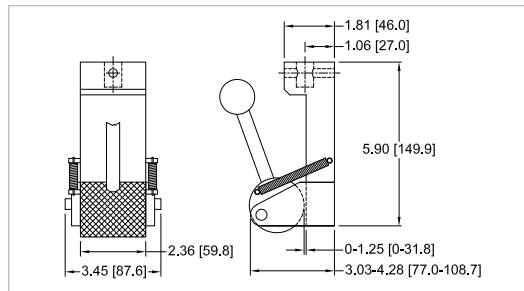



Compression / Bend / Push

Compression plates

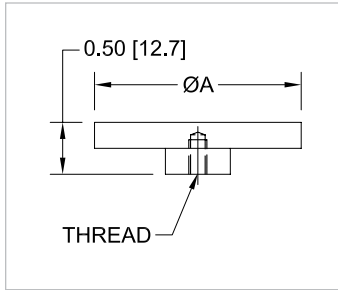

For compressing springs, foams, cartons, aerosol cans, and many other products and materials.

Model No.	Capacity lbF [N]	Weight lb [kg]	ØA	Thread	Material
G1009	200 [1,000]	0.08 [0.04]	2.0 [51.0]	#10-32 UNF	Aluminum
G1009-1	500 [2,500]	0.27 [0.12]	3.0 [76.2]	5/16-18 UNC	

G1009 includes a #10-32 M/M stud with jam nuts.

G1009-1 includes a 5/16-18M/M stud with jam nuts.

High capacity compression plates

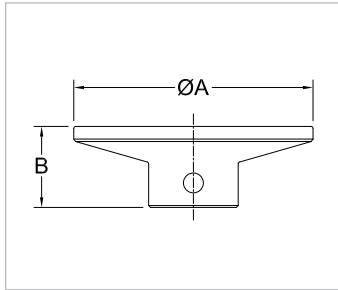

For compression spring testing, top load testing, and other applications. Integrated eye end.

Model No.	Capacity lbF [kN]	Weight lb [kg]	ØA	B	Material
G1087	2,000 [9]	1.50 [55.9]	3.78 [96.0]	1.28 [32.5]	303 SS
G1087-1	2,000 [9]	0.63 [0.29]	2.20 [55.9]	1.18 [30.0]	

Self-aligning compression plate

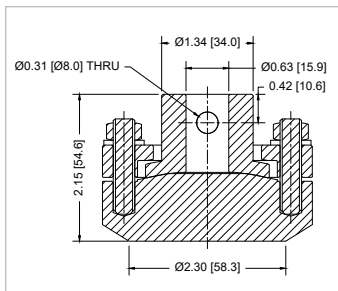

This self-aligning compression plate adjusts to the angle of the sample via four adjustable screws and nuts. Ideal for ensuring parallelism and complete sample engagement, particularly for low-deflection springs and other materials with high spring rates. Integrated eye end.

Model No.	Capacity lbF [kN]	Weight lb [kg]	Material
G1123	2.80 [1.27]	2.80 [1.27]	Steel 58 HRC, nickel-plated



Bend fixtures

Family of fixtures for 3-point and 4-point bend testing of plastics, metals, ceramics, tubing, and many other materials. Two base sizes are available, along with an upper anvil, and optional support diameters. Use a base-anvil combination for 3-point bend testing or two bases for 4-point bend testing.



3-point bend



4-point bend

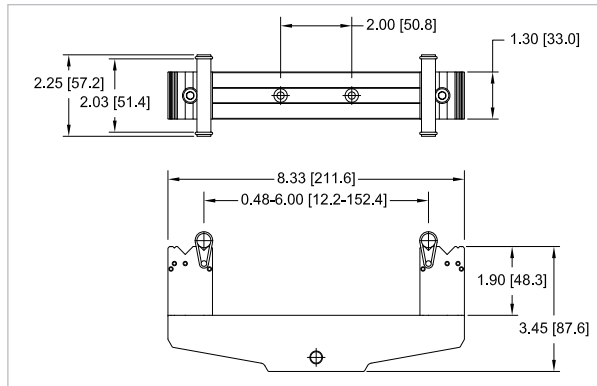

G1095

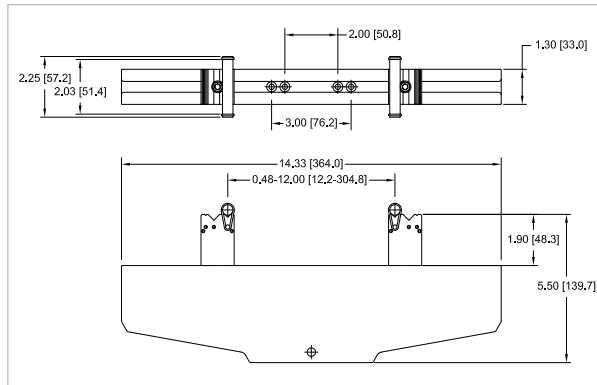

G1096

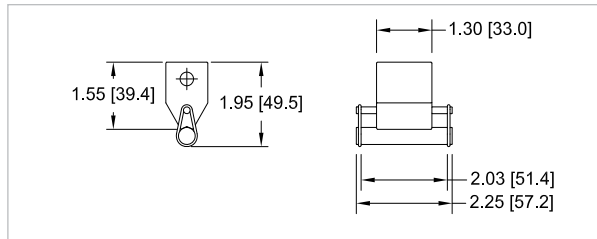

G1097



Model No.	Capacity lbF [kN]	Weight lb [kg]	Housing material	Block material	Support material	Includes
G1095	500 [2.5]	3.0 [1.3]	2024 Al	303 SS	416 SS, hardened	Two 10 mm dia. supports and o-rings
G1096	2,000 [10]	71 [3.2]	2024 Al	303 SS	416 SS, hardened	Two 10 mm dia. supports and o-rings
G1097	2,000 [10]	0.5 [0.2]	303 SS	-	416 SS, hardened	10 mm. dia. supports and o-rings

Includes mounting hardware for motorized test frames and most manual test stands, except TSA750 and TSB100. May also be mounted via integrated eye end.

Optional Items

Model No.	Description
AC1067	Supports for bend fixtures, 1 mm dia., set of 4
AC1067-1	Supports for bend fixtures, 2 mm dia., set of 4
AC1067-2	Supports for bend fixtures, 5 mm dia., set of 4





Syringe compression fixture

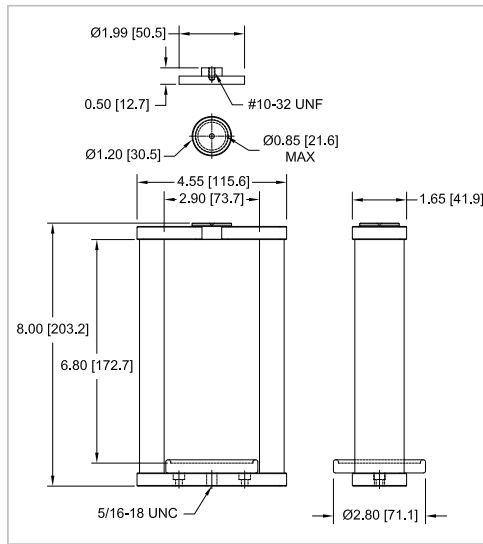

For testing compression force of a syringe plunger, as per ISO 7886-1 and other relevant standards.

Model No.	Capacity lbF [N]	Weight lb [kg]
G1089	100 [500]	1.89 [0.86]

Includes:

1. Frame
2. Replaceable blank inserts (4)
3. Cup tray
4. G1009 compression plate
5. 5/16-18 M/M stud with jam nuts
6. #10-32 x 0.5" mounting screws for test frame

Padded attachments

For applications in physical therapy and ergonomics, including muscle strength testing, job task requirements, and more.

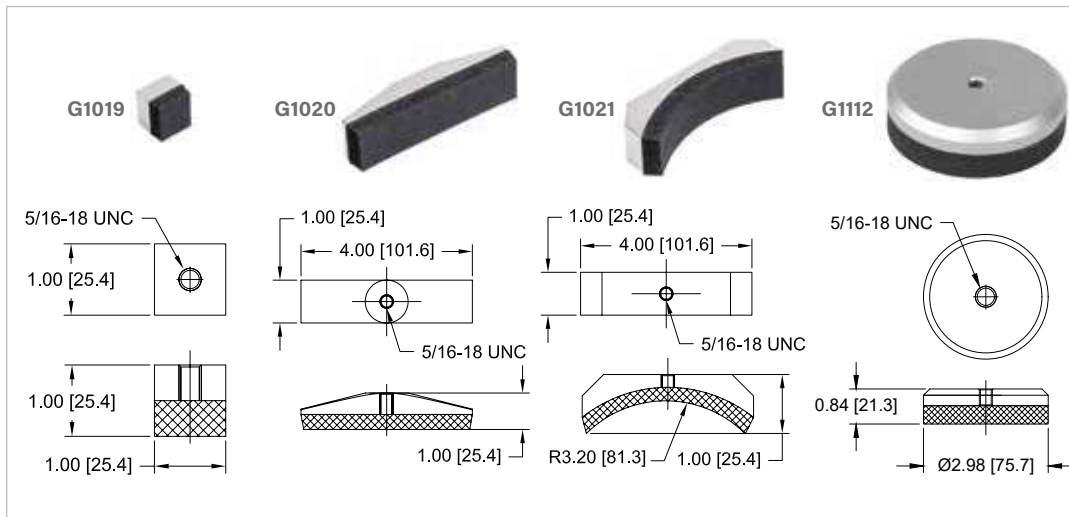

Model No.	Capacity lbF [N]	Weight lb [kg]
G1019	500 [2,500]	0.03 [0.01]
G1020	500 [2,500]	0.13 [0.06]
G1021	500 [2,500]	0.25 [0.11]
G1112	500 [2,500]	0.28 [0.13]

Includes a 5/16-18M to #10-32F thread adapter, 5/16-18 jam nut, and #10-32 jam nut.



Puncture fixture

For determining puncture resistance of plastic films and other thin materials. Includes fixture and probe. Integrated eye end.

Model No.	Capacity lbF [kN]	Weight lb [kg]
G110	1,000 [5]	Fixture: 19.0 [8.6] Probe: 0.4 [0.2]

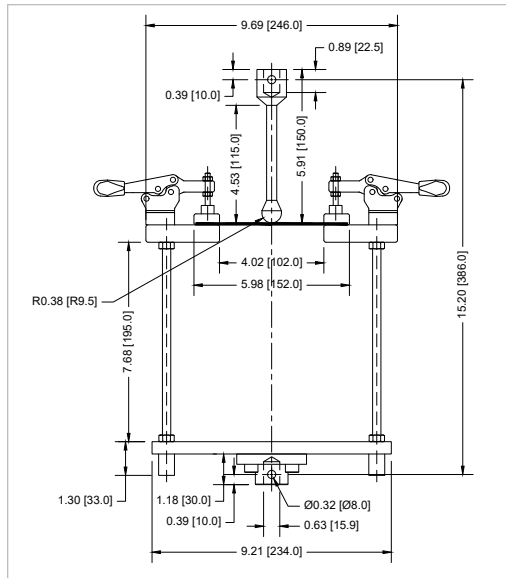

Magness Taylor Food Texture Probes

For penetrating fruits, vegetables, and other foods, for determining puncture resistance and ripeness.

Select from standard Magness Taylor diameter sizes of 5/16" and 7/16", each with a flat and rounded end.

A G1010-2 Jacobs chuck grip is required to mount a probe to a Mark-10 force sensor or force gauge.

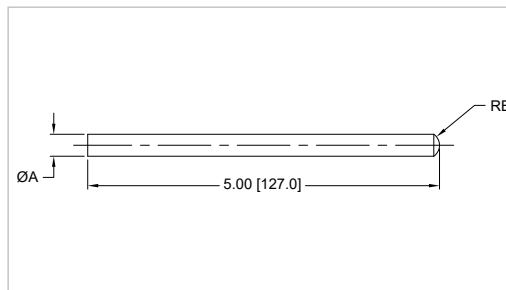

Model No.	Capacity lbF [N]	Material	$\varnothing A$	RB
G1122-1	100 [500]	303 SS	0.31 [7.9]	0.19 [4.8]
G1122-2			0.44 [11.1]	0.35 [8.9]

Puncture Fixture

For puncturing gypsum board and other materials to determine puncture resistance. Compatible with all current Mark-10 force gauges. For added safety, the spring-loaded needle retracts when not actively pushed into a material.

Model No.	Capacity lbF [N]	Weight lb [kg]
G1099	20 [100]	0.04 [0.02]

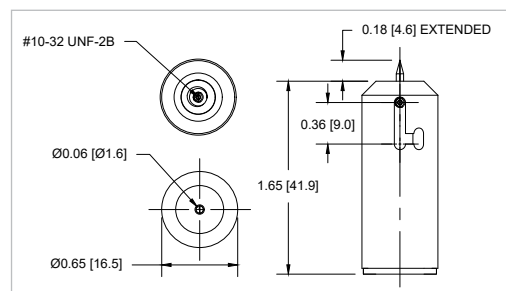



Jacobs chuck pin vises

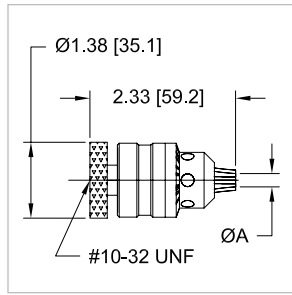

For securing pins, round samples, and fixtures.

Model No.	Capacity lbF [N]	Weight lb [kg]	ØA
G1010	30 [150]	0.35 [0.16]	0.062 - 0.375 [1.6 - 9.5]
G1010-1		0.25 [0.11]	0.028 - 0.25 [0.7 - 6.3]
G1010-2		0.66 [0.30]	0.078 - 0.5 [2.0 - 12.7]

Includes a #10-32 M/M stud with jam nuts.

Rubber tip

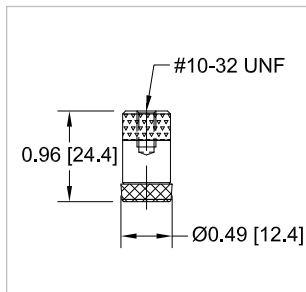

Simulates a finger for testing pushbuttons, membrane switches, touch-screen panels, keyboards, etc.

Model No.	Capacity lbF [N]	Weight lb [kg]
G1011	50 [250]	0.01 [0.004]

Includes a #10-32 M/M stud with jam nuts.

Torque / Force

Universal bottle grip

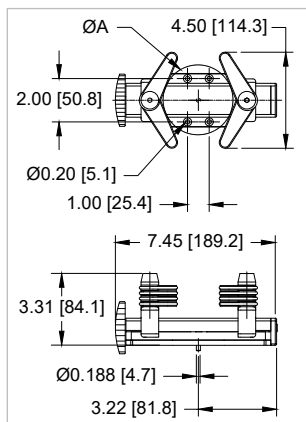

For gripping bottles and containers in closure torque testing applications. Eight rubber edged gripping arms secure a wide range of sample shapes and sizes and may be individually positioned at angles up to 180°. Mounts directly to Series TST torque test stands, most force test stands, and G1109 90° peel fixture for applications such as top load testing and 90° peel testing.

Model No.	Capacity lbFin [Nm]	Weight lb [kg]	ØA
G1023	100 [11.3]	1.50 [0.7]	4.80 [122.0] MAX

Model No.	Description
AC1080	Adapter, G1023 to G1109 peel fixture

G1023 includes four #10-32 x 1" mounting screws for Series TST test stands or G1068 adapter.

G1068 includes mounting hardware for the G1023 fixture and the following test stands: ESM303, ESM1500/750 (w/AC1055 plate), ES30, TSC1000, TSF, ES10/ES20 (w/AC1060 plate)



Universal V-jaw grip

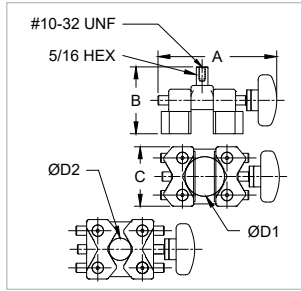

For gripping round objects. Serrated, reversible aluminum jaws effectively grip a wide range of sample shapes and sizes. Mounts directly to Jacobs chucks, force gauges, and test stands.

Model No.	Torque Capacity lbFin [Nm]	Force Capacity lbF [N]	Weight lb [kg]
G1053	100 [11.3]	100 [500]	0.40 [0.18]

A	B	C	ØD1*	ØD2*
3.1 [78.7]	1.77 [45.0]	1.6 [40.6]	1.10 - 1.55 [27.9 - 39.4]	0.65 - 1.10 [16.5 - 27.9]

* Reverse the jaws to switch between ØD1 and ØD2.

Includes a #10-32 M/M stud with jam nuts.

Universal cap grip

For securing caps, lids, and other similar items for torque and pull testing. Accommodates a wide range of sample sizes, and can be used manually with a torque gauge or mounted to a test stand.

Model No.	Capacity	Weight lb [kg]
G1058	100 lbFin [11.3 Nm] or 50 lbF [250 N]	0.65 [0.29]

A	B	C	D	E	ØMIN - ØMAX
0.9 [22.9]	3.8 [96.5]	3.2 [81.3]	2.8 [71.1]	1.0 [25.4]	0.20 - 3.50 [5.1 - 89.0]

Includes #10-32 M/M stud with jam nuts.

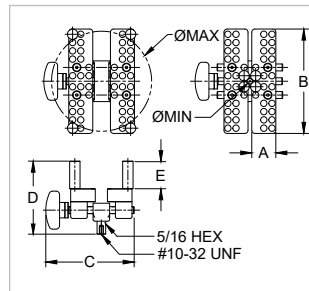

Jacobs chuck grips

For securing round samples, fixtures, or bits in torque applications. Mounts directly to series TST torque test stands.

Model No.	Capacity	Weight lb [kg]	ØA	ØB	ØC
G1022-1					0.028 - 0.250 [0.7 - 6.3]
G1022-2	100 lbFin [11.3 Nm]	0.50 [0.23]	N/A	0.188 [4.7]	0.062 - 0.375 [1.6 - 9.5]
G1022-3					0.078 - 0.500 [2.0 - 12.7]

Includes mounting hardware for Series TST torque test stands.

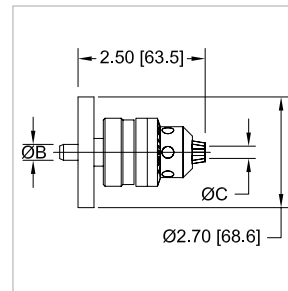



Basic Attachments & Adapters

Hooks

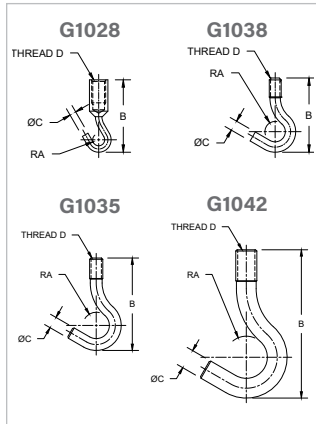

For general pull testing applications.

Model No.	Capacity lbF [N]	Weight lb [kg]	RA	B	ØC	D
G1028	20 [100]	0.01 [0.01]	0.05 [1.3]	1.00 [25.4]	0.10 [2.5]	#10-32F
G1038	200 [1,000]	0.02 [0.01]	0.20 [5.1]	1.50 [38.1]	0.19 [4.8]	#10-32M
G1035	500 [2,500]	0.05 [0.02]	0.30 [7.6]	2.19 [55.6]	0.28 [7.1]	5/16-18M
G1042	1,000 [4,500]	0.32 [0.15]	0.5 [12.7]	3.52 [89.4]	0.45 [11.4]	1/2-20M

Snap hook

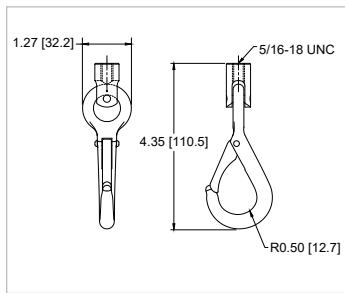

For general pull testing applications. Features a snap clasp, for added safety. Swiveling action ensures proper alignment.

Model No.	Capacity lbF [N]	Weight lb [kg]
G1107	500 [2,500]	0.3 [0.14]

Flat heads

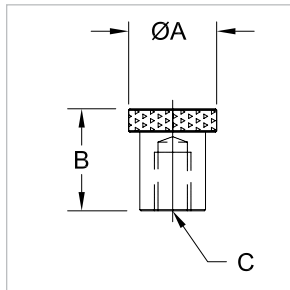

For compression testing of buttons, small springs, membrane switches, etc.

Model No.	Capacity lbF [N]	Weight lb [kg]	ØA	B	C
G1029	200 [1,000]	0.01 [0.005]	0.5 [12.7]	0.5 [12.7]	#10-32F
G1036	500 [2,500]	0.06 [0.027]	0.75 [19.1]	0.87 [22.1]	5/16-18F

Swivel adapters

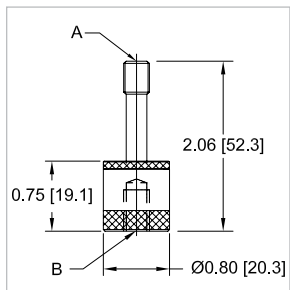

For use between grips and force gauges and sensors, to provide a swiveling action for proper sample alignment.

Model No.	Capacity lbF [N]	Weight lb [kg]	A	B
G1018-1	200 [1,000]	0.12 [0.05]	#10-32M	#10-32F
G1018-2	500 [2,500]	0.27 [0.12]	5/16-18M	5/16-18F



Extension rods

For use between force gauges, sensors, grips, and attachments.
Not recommended for compression applications.

Model No.	Capacity lbF [N]	Weight lb [kg]	A	ØB	C	D
G1024	200 [1,000]	0.05 [0.023]	5.0 [127.0]	0.25 [6.4]	#10-32F	#10-32M
G1024-1		0.02 [0.009]	2.0 [50.8]			
G1024-2		0.01 [0.005]	1.0 [25.4]			
G1031	500 [2,500]	0.25 [0.113]	5.0 [127.0]	0.50 [12.7]	5/16-18F	5/16-18M
G1031-1		0.10 [0.045]	2.0 [50.8]			
G1031-2		0.25 [0.113]	1.0 [25.4]			

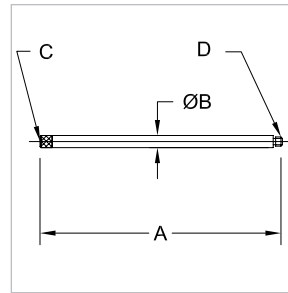

Chisel points

For compression testing applications.

Model No.	Capacity lbF [N]	Weight lb [kg]	A	ØB	C
G1025	200 [1,000]	0.003 [0.001]	0.50 [12.7]	0.25 [6.4]	#10-32F
G1032	500 [2,500]	0.040 [0.018]	1.00 [25.4]	0.50 [12.7]	5/16-18F

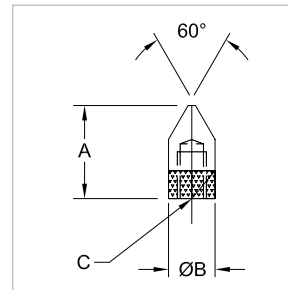

Cone points

For various compression and puncture testing applications.

Model No.	Capacity lbF [N]	Weight lb [kg]	A	ØB	C
G1026	200 [1,000]	0.003 [0.001]	0.50 [12.7]	0.25 [6.4]	#10-32F
G1033	500 [2,500]	0.030 [0.014]	1.00 [25.4]	0.50 [12.7]	5/16-18F

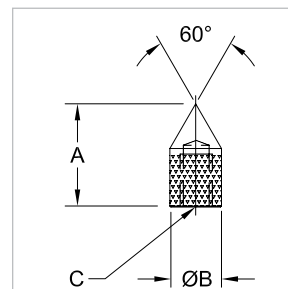

V-grooves

For compression testing of round or odd-shaped samples.

Model No.	Capacity lbF [N]	Weight lb [kg]	A	ØB	C	D
G1027	200 [1,000]	0.004 [0.002]	0.50 [12.7]	0.25 [6.4]	#10-32F	0.08 [2.0]
G1034	500 [2,500]	0.040 [0.018]	1.00 [25.4]	0.50 [12.7]	5/16-18F	0.25 [6.4]

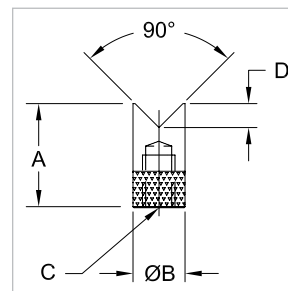



Thread adapters & couplings

For use between gauges, sensors, test stands grips, and attachments. Suitable for tension and compression applications.

	Model No.	Capacity lbF [N]	Length in [mm]	Thread A	Thread B
	G1050	100 [500]	0.75 [19.1]	#4-40M	#10-32F
	G1051		0.55 [14.0]	#4-40M	#10-32M
	G1113		0.75 [19.1]	M3M	#4-40F
	G1039	200 [1,000]	0.75 [19.1]	#10-32F	#10-32F
	G1030		0.50 [12.7]	5/16-18M	#10-32F
	G1057		1.00 [25.4]	#10-32F	M6F
	G1060		0.50 [12.7]	#10-32M	#10-32M
	G1047		0.75 [19.1]	#10-32M	M4F
	G1048		0.75 [19.1]	M4M	#10-32F
	G1054		0.75 [19.1]	M6M	#10-32F
	G1063		1.30 [33.0]	#10-32M	5/16-18F
	G1040		0.92 [23.4]	5/16-18M	5/16-18M
	G1037		1.00 [25.4]	5/16-18F	5/16-18F
	G1049	1.25 [31.8]	M6M	5/16-18F	
	G1059	500 [2,500]	1.13 [28.7]	5/16-18F	1/2-20F
	G1041		1.06 [26.9]	1/2-20M	5/16-18M
	G1066		0.75 [19.1]	5/16-18F	1/2-20M
	G1067		0.75 [19.1]	1/2-20M	10-32F
	G1069		1.25 [31.8]	5/16-18F	1/4-28M
	G1091	1,000 [5,000]	1.30 [33.0]	1/2-20F	1/2-20F
	G1044		Adapter plate, 1/2-20F. Compatible with many test stands. Mounting hardware included.		

Studs & jam nuts

For use between test stands, grips, and attachments.

	Model No.	Capacity lbF [N]	Thread	Length
	AC 1082	100 [500]	#10-32M	0.75 [19.1]
	AC 1082-1	500 [2,500]	5/16-18M	1.00 [25.4]
	AC 1082-2	2,000 [9,000]	1/2-20M	1.50 [38.1]



Eye end adapters

These adapters provide a commonly accepted industry method of attaching fixtures to force sensors and test frames. They prevent grip rotation and allow for quick removal and installation.

Several thread sizes and variations are available to suit most common test frames, force sensors, grips, and force gauges. Eye ends and adapters are available individually or as kits.

◀ Eye end adapter is shown with a Mark-10 wedge grip and test frame.

Item No.	Model No.	Description
1	G1079	Lock ring, 3/4-16
2	G1081	Eye end, #10-32M
	G1081-1	Eye end, 5/16-18M
	G1081-2	Eye end, 1/2-20M
	G1081-3	Eye end, 1/4-28M
3	G1080	Anchor pin
4	G1083	Eye end adapter, #10-32M
	G1083-1	Eye end adapter, 5/16-18M
	G1083-2	Eye end adapter, 1/2-20M
5	G1084	Washer, 0.20 ID
	G1084-1	Washer, 0.32 ID
	G1084-2	Washer, 0.51 ID
6	G1082	Eye end, #10-32F
	G1082-1	Eye end, 5/16-18F
7	G1088	Spanner wrench

Force sensor / test frame configuration

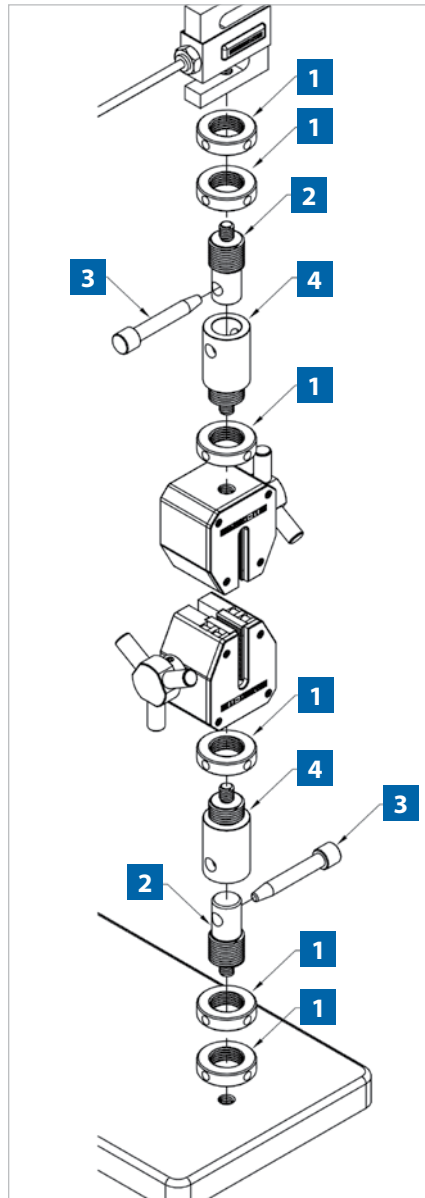

Force gauge configuration

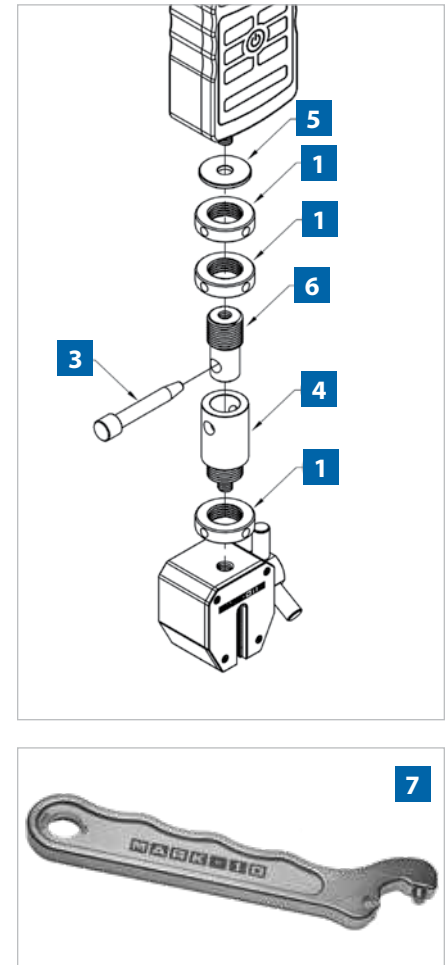



Eye end adapters - kits

Test Frame Base / Force Sensor Adapter Kits

Model No.	Description	Compatibility	Includes
AC1047	Test frame base adapter kit, #10-32M	Test frame bases w/ #10-32 mounting	1x G1081 eye end 1x G1080 anchor pin 2x G1079 lock ring
AC1047-1	Test frame base adapter kit, 5/16-18M	Test frame bases w/ 5/16-18 mounting	1x G1081-1 eye end 1x G1080 anchor pin 2x G1079 lock ring
AC1047-2	Test frame base / force sensor adapter kit, 1/2-20M	Test frame bases w/ 1/2-20 mounting Models MR01-300 / -500 / -750 / -1000 / -1500 / -2000 force sensors Models MR07-300 / -500 / -750 / -1000 / -1500 / -2000 force sensors Models FS06-300 / -500 force sensors	1x G1081-2 eye end 1x G1080 anchor pin 2x G1079 lock ring
AC1047-3	Force sensor adapter kit, 1/4-28M	Models MR01-50 / -100 / -200 force sensors Models MR07-50 / -100 / -200 force sensors Models FS06-50 / -100 / -200 force sensors	1x G1081-3 eye end 1x G1080 anchor pin 2x G1079 lock ring
AC1047-4	Force sensor adapter, Series R03, #10-32M	Series R03 force sensors	1x G1081 eye end 1x G1080 anchor pin 2x G1079 lock ring 1x G1084 washer



AC1047



AC1047-1



AC1047-2



AC1047-3



AC1047-4

Grip Adapter Kits

Model No.	Description	Compatibility	Includes
AC1046	Grip adapter kit, #10-32M	Grips with #10-32 mounting	1x G1083 eye end adapter 1x G1079 lock ring
AC1046-1	Grip adapter kit, 5/16-18M	Grips with 5/16-18 mounting	1x G1083-1 eye end adapter 1x G1079 lock ring
AC1046-2	Grip adapter kit, 1/2-20M	Grips with 1/2-20 mounting	1x G1083-2 eye end adapter 1x G1079 lock ring



AC1046



AC1046-1



AC1046-2

Force Gauge / Force Sensor Adapter Kits

Model No.	Description	Compatibility	Includes
AC1045	Force gauge adapter kit, #10-32F	Force gauges up to 100 lbf capacity Series FS05 force sensors up to 100 lbf load cells	1x G1082 eye end 1x G1084 washer 2x G1079 lock ring 1x G1080 anchor pin
AC1045-1	Force gauge adapter kit, 5/16-18F	Force gauges with 200, 300, and 500 lbf capacities Models FS05-200/-300/-500 force sensors	1x G1082-1 eye end 1x G1084-1 washer 2x G1079 lock ring 1x G1080 anchor pin
AC1045-2	Force gauge adapter kit, 1/2-20M	Models M5-750 - M5-2000 force gauges	1x G1081-2 eye end 1x G1084-2 washer 2x G1079 lock ring 1x G1080 anchor pin



AC1045



AC1045-1



AC1045-2



Eye end adapters - individual attachments

G1081-X eye ends

Model No.	A	Thread	Weight lb [kg]	Capacity lbF [kN]
G1081	1.82 [46.2]	#10-32	0.13 [0.06]	200 [1]
G1081-1	1.88 [47.8]	5/16-18	0.14 [0.06]	500 [2.5]
G1081-2	2.02 [51.3]	1/2-20	0.15 [0.07]	2,000 [10]
G1081-3	1.87 [47.5]	1/4-28	0.13 [0.06]	200 [1]

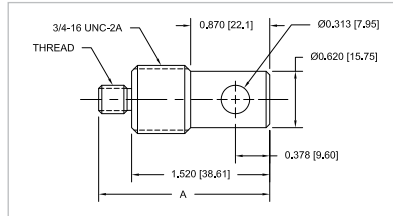

G1082-X eye ends

Model No.	Thread	Weight lb [kg]	Capacity lbF [kN]
G1082	#10-32	0.13 [0.06]	200 [1]
G1082-1	5/16-18	0.14 [0.05]	500 [2.5]

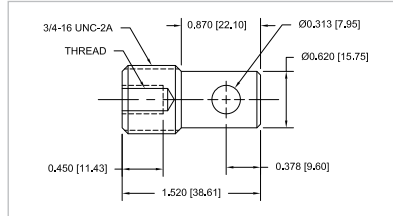

G1083-X eye ends

Model No.	A	Thread	Weight lb [kg]	Capacity lbF [kN]
G1083	2.10 [53.3]	#10-32	0.26 [0.12]	200 [1]
G1083-1	2.16 [54.9]	5/16-18	0.26 [0.12]	500 [2.5]
G1083-2	2.30 [58.4]	1/2-20	0.28 [0.13]	2,000 [10]

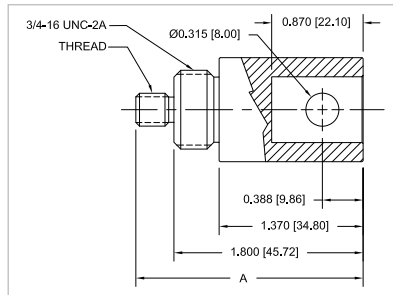

G1084-X jam washers

Model No.	ØA	Weight lb [kg]
G1084	0.20 [5.1]	0.03 [0.01]
G1084-1	0.32 [8.2]	0.03 [0.01]
G1084-2	0.51 [12.9]	0.03 [0.01]

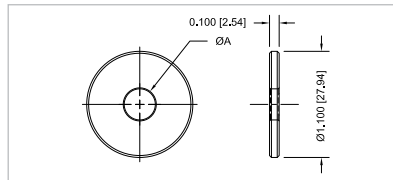

G1079 lock ring

Model No.	Weight lb [kg]
G1079	0.07 [0.03]

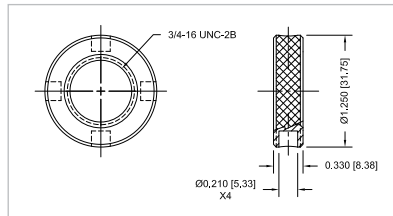

G1080 anchor pin

Model No.	Weight lb [kg]
G1080	0.06 [0.03]

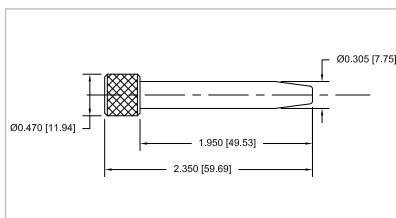

G1088 spanner wrench





Grip Adapter Kits for Instron Frames and Load Cells



AC1088-1



AC1088-8



AC1088-9



AC1090-1



AC1090-3

Model No.	Description	Compatibility	Includes
AC1088-1	Grip adapter kit, eye end, #10-32M	Mark-10 grips with #10-32 thread to Instron frames and load cells	1x G1083 eye end adapter 2x G1079 lock ring
AC1088-8	Grip adapter kit, eye end, 5/16-18M	Mark-10 grips with 5/16-18 thread to Instron frames and load cells	1x G1083-1 eye end adapter 2x G1079 lock ring
AC1088-9	Grip adapter kit, eye end, 1/2-20M	Mark-10 grips with 1/2-20 thread to Instron frames and load cells	1x G1083-2 eye end adapter 2x G1079 lock ring
AC1090-1	Eye end adapter kit, 0.23" dia.	Mark-10 grips with eye end mounting to Instron frames and load cells	1x G1083-2 eye end adapter 2x G1079 lock ring 1x G1080 anchor pin
AC1090-3	Eye end adapter kit, 0.47" dia.	Mark-10 grips with eye end mounting to Instron frames and load cells	1x G1083-2 eye end adapter 2x G1079 lock ring 1x G1080 anchor pin



Hardware

Double handle grips

For use in ergonomics testing, job task analysis, and physical therapy. Includes four gauge mounting screws.



Model No.	Description
AC1002	Double handle grip for Series 7/5/4 gauges
AC1003	Double handle grip for Series 3/2 gauges

Single handle grips

For use in ergonomics testing, job task analysis, and physical therapy. Includes four gauge mounting screws.



Model No.	Description
AC1002-1	Single handle grip for Series 7/5/4 gauges
AC1003-1	Single handle grip for Series 3/2 gauges

Inline adapters for force gauges

These adapters allow a force gauge to be used in inline pull testing or weighing applications. A 5/16-18 threaded hole at each end is axially aligned with the load cell shaft in the force gauge, for mounting hooks or other attachments. Three adapters are offered, accommodating Mark-10 force gauges with capacities up to 500 lbF (2.5 kN). Includes four gauge mounting screws and one 5/16-18 male/male stud with jam nuts. 500 lbF (2.5 kN) capacity.



Model No.	Description
AC1073-1	Inline adapter, Series 3/2 force gauges
AC1073-2	Inline adapter, Series 7/5*/4 force gauges
AC1073-3	Inline adapter, Series E force gauges

* Up to 500 lbF (2,500 N) capacities

Tabletop stand for indicators and torque gauges

Features an angle adjustment and thru holes for workbench mounting. Includes four gauge mounting screws. Compatible with Mark-10 indicators and Series TT03 torque gauges.

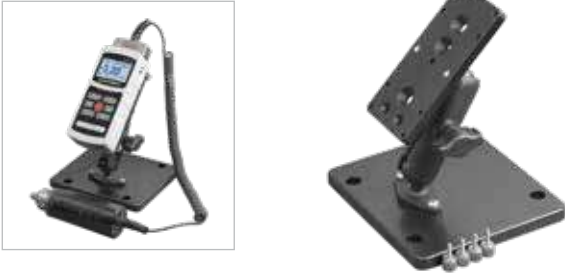

Model No.	Description
AC1100	Stand, tabletop, indicator/torque gauge

Force gauge mounting plate kits

Universal kits suitable for all Mark-10 force gauges in OEM and custom mounting applications. Includes gauge mounting screws and plate mounting screws.



Model No.	Description
AC1052	Mounting plate kit, 0.12 - 500 lbf [0.5 - 2,500 N] Mark-10 force gauges
AC1007	Mounting plate kit, 0.12 - 2,000 lbf [0.5 N - 10 kN] Mark-10 force gauges

Tabletop mounting kits for torque sensors

For securing Series R50, R52, and Models MR55-200/400 torque sensors to a workbench.



Model No.	Description
AC1006	Mounting kit, R52, tabletop
AC1007	Mounting kit, R50, tabletop
AC1010	Mounting kit, MR55-200/MR55-400, tabletop

Competitor gauge mounting kits

Model No.	Description	Compatible Test Stands
AC1020	Gauge mounting kit, Chatillon DFE/DFS/DFX/LG	ES10, ES20, ES30, ESM303
AC1021	Gauge mounting kit, Chatillon DFM	
AC1022	Gauge mounting kit, Chatillon DFIS	
AC1023	Gauge mounting kit, Mecmesin AFG/BFG	
AC1024	Gauge mounting kit, Imada	
AC1025	Gauge mounting kit, Shimpo FGV/FGE	
AC1037	Gauge mounting kit, Chatillon DFE/DFS/DFX/LG	TSA750(H), TSC1000(H), TSF(H)
AC1038	Gauge mounting kit, Chatillon DFM	
AC1039	Gauge mounting kit, Chatillon DFIS	
AC1040	Gauge mounting kit, Mecmesin AFG/BFG	
AC1041	Gauge mounting kit, Imada ZT/DS2/DPZ/DPS	
AC1042	Gauge mounting kit, Shimpo FGV/FGE	
AC1061	Mark-10 force gauges to 500 lbf / 2,500 N	Chatillon TCD200, TCM201, LTCM series
AC1069	Mark-10 force gauges to 500 lbf / 2,500 N	Mecmesin test stands

Axial compensator

Compensates for axial movement in torque tests of threaded fasteners, bottle caps, etc. The axial compensator has a hex tail which fits into the chuck of a Series R50 or TT03 torque gauge, and includes mounting hardware to mount to a G1053 or G1058 grip.



Model No.	Description
AC1029	Axial compensator

Test stand mounting kits for remote sensors

Refer to the compatibility table below:



Model No.	Sensors	Test Stands
AC1015	Series R51	Series TST torque test stands
AC1016	Models MR55-200 - MR55-400	Series TST torque test stands
AC1016-1	Models MR55-20 - MR55-100	Series TST torque test stands
AC1018	Series R01, Series R03	All force test stands, except ESM303(H), ESM750/ESM1500, and TSB100. Not compatible with Series F.
AC1062	Series R01, Series R03	ESM303



Calibration Kits

Cap torque tester calibration kit

For calibrating Series TT01 cap torque tester. The kit contains a complete set of attachments required to mount the tester to a bench, as well as the necessary brackets and cable to mount weights (weights not included).



Model No.	Description
AC1036	Calibration kit for cap torque testers

Wire pull tester calibration kit

For calibrating a WT3-200, WT3-201, or WT3-201M wire crimp pull tester. The kit contains a complete set of attachments required to mount the tester to a bench, as well as the necessary brackets to mount weights (weights not included).



Model No.	Description
AC1049	Calibration kit for wire crimp pull testers

Power & Communication

Communication adapters

RSU100



MU100



UXU100



Model No.	Description
RSU100	Adapter, RS-232 to USB
MU100	Adapter, Mitutoyo to USB, 6' cable length
UXU100	USB communication adapter

Footswitch for Series 7 instruments

Automates common force gauge functions for improved testing ergonomics and efficiency, eliminating the need for multiple key presses. Up to three functions may be programmed for a single footswitch activation, such as request reading, zero the display, etc.



Model No.	Description
AC1051	Footswitch for Series 7 instruments

AC adapter/chargers

110V and 220V models available, for use with all Mark-10 gauges, indicators, and testers.*

Model No.	Description
AC1030	AC adapter / charger, 110V
AC1031	AC adapter / charger, 220V EUR
AC1032	AC adapter / charger, 220V UK
AC1035	AC adapter / charger, 220V AUS

* Except legacy series MG and MGT gauges manufactured prior to September, 2010.



Replacement battery

Rechargeable 8.4V NiMH battery, for use with Mark-10 gauges, indicators, and testers.



Model No.	Description
AC1118	Battery, rechargeable, 8.4V

Communication cables

Various cables are available for communicating between Mark-10 gauges, indicators, test stands, PCs, printers, PLCs, and other devices.

	Model No.	Description	Compatible Instruments
	AC1116 (09-1349)	USB cable, type C to A	Series F test frames with EasyMESUR® to PC
	AC1114 (09-1214)	Interface cable, gauge to test stand crosshead	Series 7, 5, 4 instruments to ESM303, ESM1500 test stands
	AC1115 (09-1252)	Interface cable, indicator to test stand crosshead	Model M7I and M5I indicators to ESM303H test stand
	AC1111 (09-1165)	USB cable, type micro B to A	Series 7, 5, 4, 3, TT01, TT02, TT03, TT05, WT3-201(M) instruments to PC
	AC1107 (09-1158)	USB cable, type B to A	Series F test frames, ESM303, ESM750, ESM1500 test stands to PC
	AC1109 (09-1163)	Serial cable, gauge to RS-232, DB-9	Series 7, 5, 4, TT01, TT02, TT05, WT3-201(M) instruments
	AC1110 (09-1164)	Cable, gauge to Mitutoyo SPC	Series 7, 5, 4, TT01, TT02, TT05, WT3-201(M) instruments
	AC1112 (09-1166)	Analog cable, gauge to dual banana plug	Series 7, 5, 4, TT01, TT02, TT05, WT3-201(M) instruments
	AC1105 (09-1066)	Cable, travel display to Mitutoyo SPC	Mitutoyo travel display mounted to ES30, TSA750(H), TSB100, TSC1000(H), and TSF(H) test stands

Cables for legacy products are also available. See website for details.



Test Frame Accessories



Double column extension

Accommodate up to a 20 in. [508 mm] wide sample, or \varnothing 21.5 in [\varnothing 546 mm] round sample. Three heights are available – 6, 12 and 24 in [150, 300, and 600 mm]. Base contains rows of T-slots, with available fixture mounting plates.

Compatible with:

Models F105 / F305 / F505 test frames - these test frames include a base plate with matrix of threaded holes, which may be mounted to the column extension's base.

Model ESM303 test stand - if a base plate with matrix of threaded holes is needed, add part no. AC1096.

Model No.	Description
AC1095-1	Double column extension for F105, F305, F505, and ESM303, 6"
AC1095-2	Double column extension for F105, F305, F505, and ESM303, 12"
AC1095-3	Double column extension for F105, F305, F505, and ESM303, 24"
AC1096	Mounting plate kit, matrix of threaded holes (suggested for ESM303; included with F105/F305/F505)



Shields for test frames

Provide pinch and sample debris protection for the operator. An electrical interlock prevents test frame operation while the door is open. The test frame's control panel and remote emergency stop (applicable models, only) mount to the shield's extruded frame.

Model No.	Description
AC1092-1	Shield, 51.9" height
AC1092-2	Shield, 34.4" height
AC1092-3	Shield, 51.9" height, ESM303 with column extension up to 24"
AC1092-4	Shield, 34.4" height, ESM303

USB hub

Test frame-mounted 4-port USB hub improves cable management and conveniently accommodates peripherals, such as a flash drive, barcode scanner, etc.

Compatible with Series F + IntellIMESUR® test frames.



Model No.	Description
AC1093	USB hub

Force sensor - test stand mounting kit

For securing any Series R01 or R03 force sensor to any of the following Mark-10 force test stands:

- ES10 / ES20
- ES30
- TSA750 / TSA750H
- TSC1000 / TSC1000H
- TSF / TSFH



Model No.	Description
AC1018	Mounting kit, R01/R03 to test stand

The kit contains brackets and screws with the following thread sizes: #10-32, 1/4-28, 5/16-18, and 1/2-20.

Adapter for Series FS Force Sensors

Adapts a Series FS force sensor or PTAF sensor adapter to Plug & Test® type interface, for ease of external calibration via a Mark-10 indicator. Also permits mounting of a Series FS05 sensor to Models F755, F755S, F1505, and F1505S test frames.



AC1084



AC1083

Model No.	Description
AC1083	Adapter, FS05 sensor / PTAF adapter, to Plug & Test® connector / F755, F755S, F1505, F1505S test frames, 10 in / 250 mm cable
AC1084	Extension cable, 12 in / 305 mm, Plug & Test®, male/female



Force Gauges

Series 7

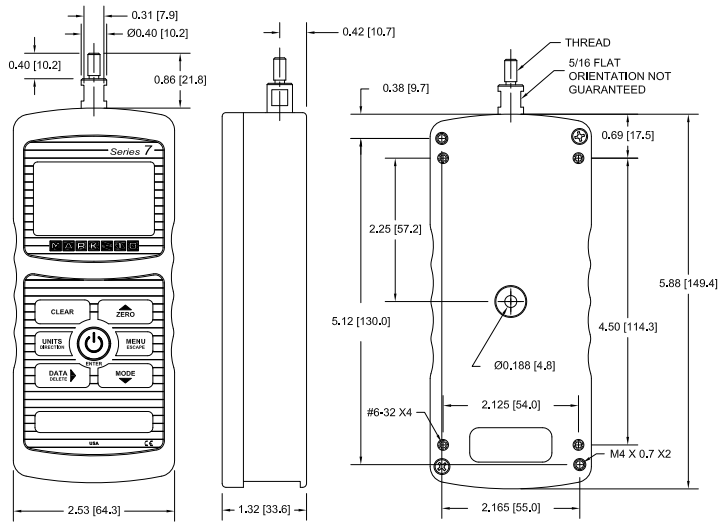

Model No.	Thread
M7-012 - M7-100	#10-32M UNF
M7-200 - M7-500	5/16-18M UNC

Series 5
Models
M5-012 -
M5-500

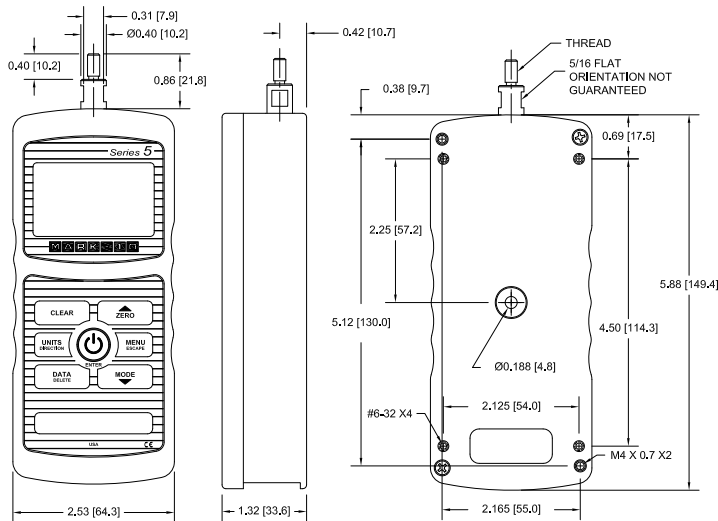

Model No.	Thread
M5-012 - M5-100	#10-32 UNF
M5-200 - M5-500	5/16-18 UNC

Series 5
Models
M5-750 -
M5-2000

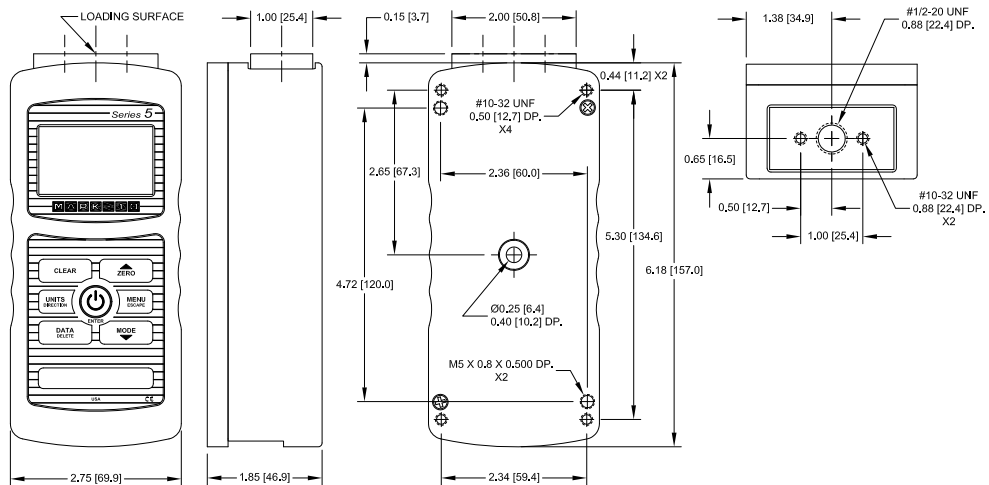



Dimensional Drawings ▶ Force Gauges

Series 4

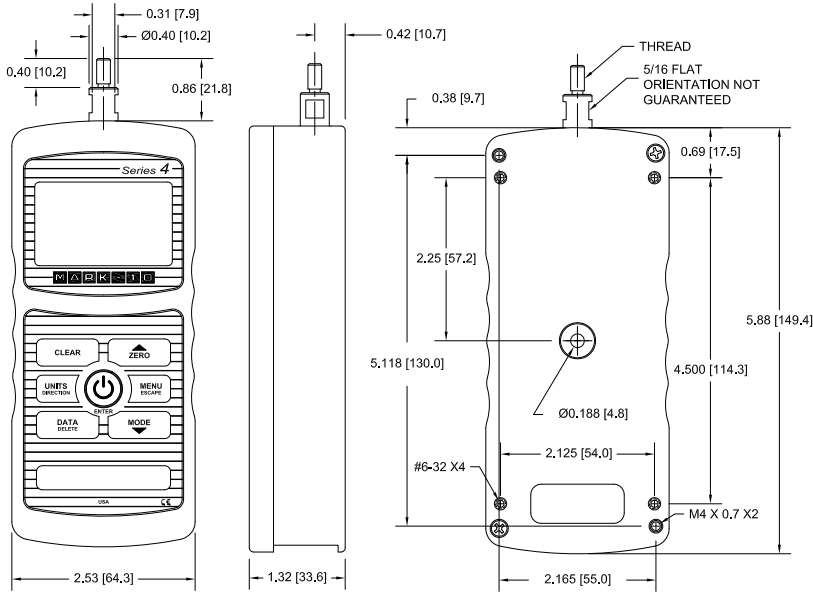

Model No.	Thread
M4-012 - M4-100	#10-32 UNF
M4-200 - M4-500	5/16-18 UNC

Series 3

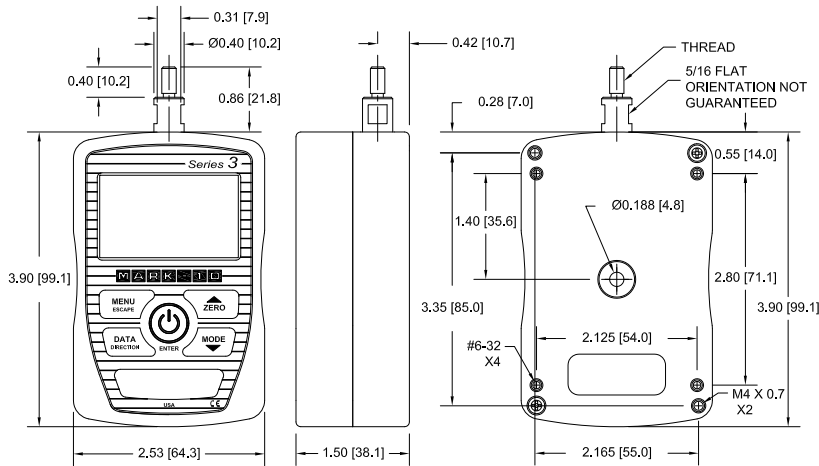

Model No.	Thread
M3-012 - M3-100	#10-32 UNF
M3-200 - M3-500	5/16-18 UNC

Series 2

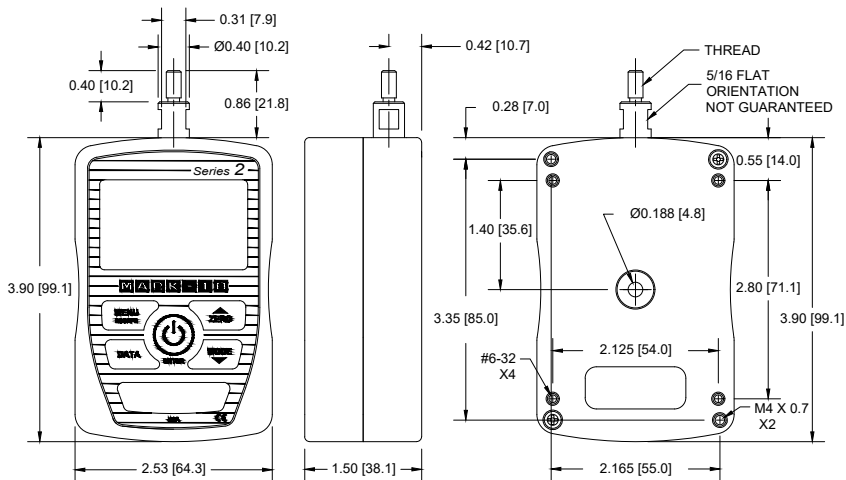

Model No.	Thread
M2-2 - M2-100	#10-32 UNF
M2-200 - M2-500	5/16-18 UNC



Ergonomics Force Gauges

Series E

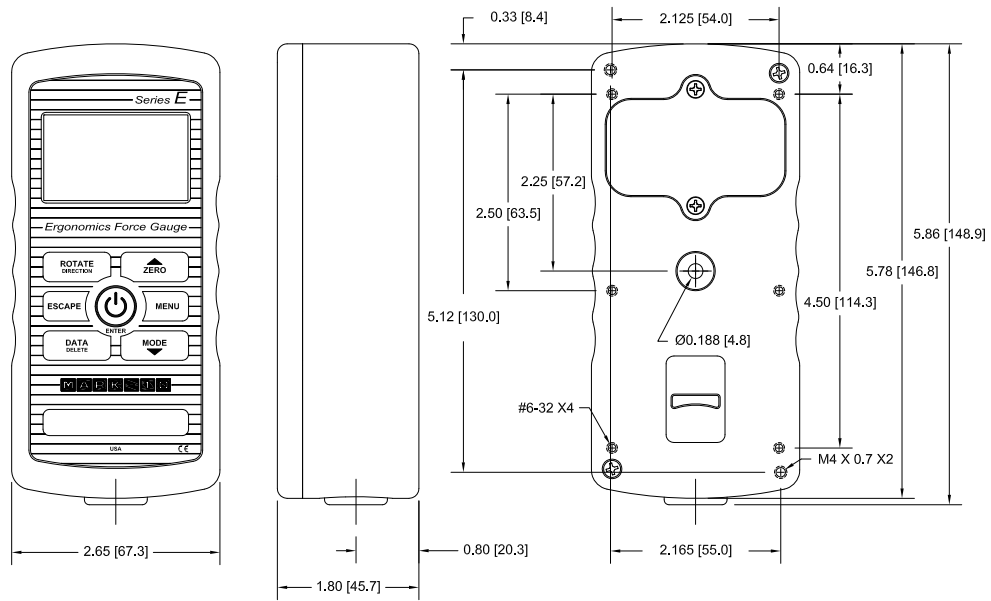

Torque Gauges

Series TT01

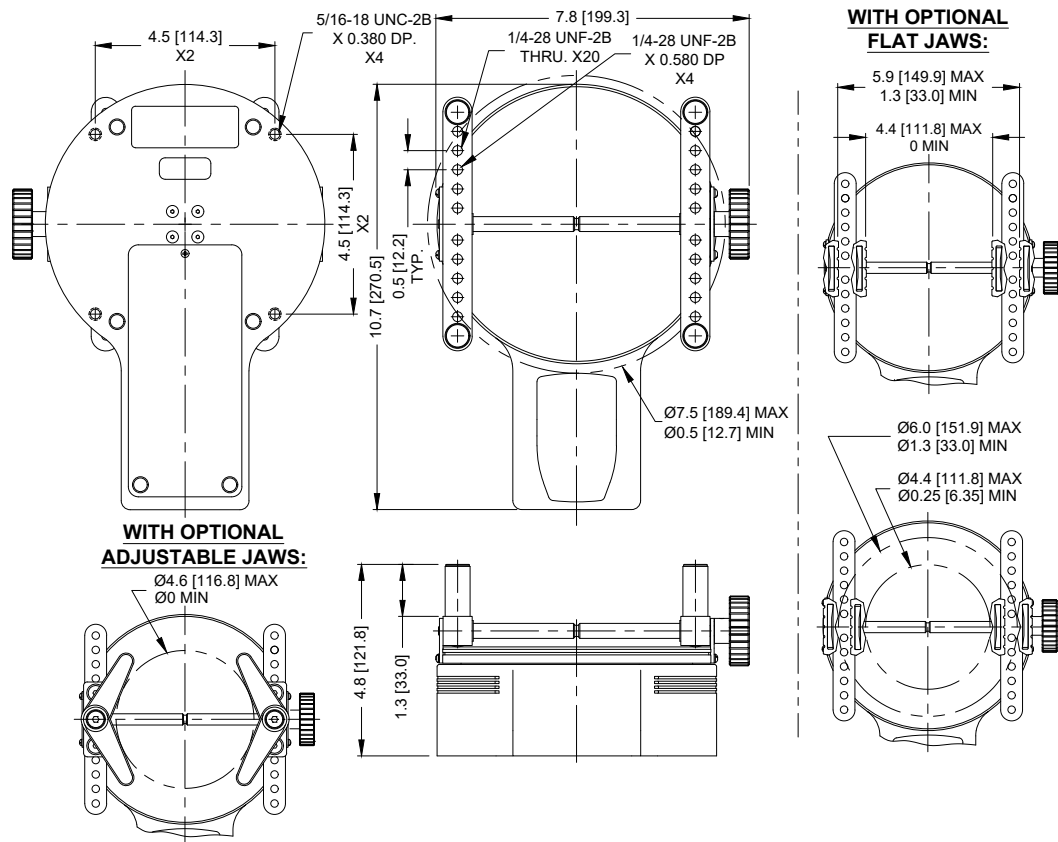



Series TT02

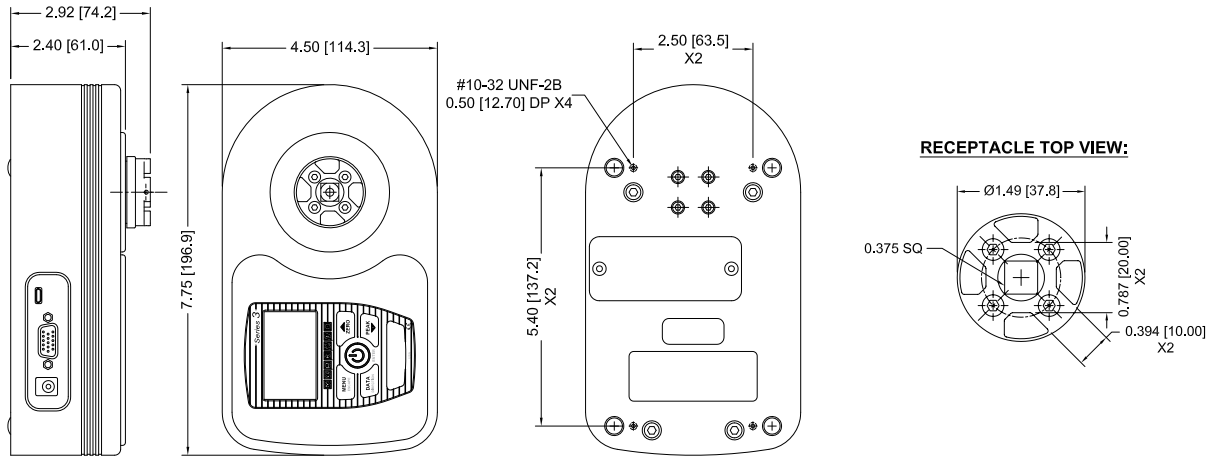

Series TT03

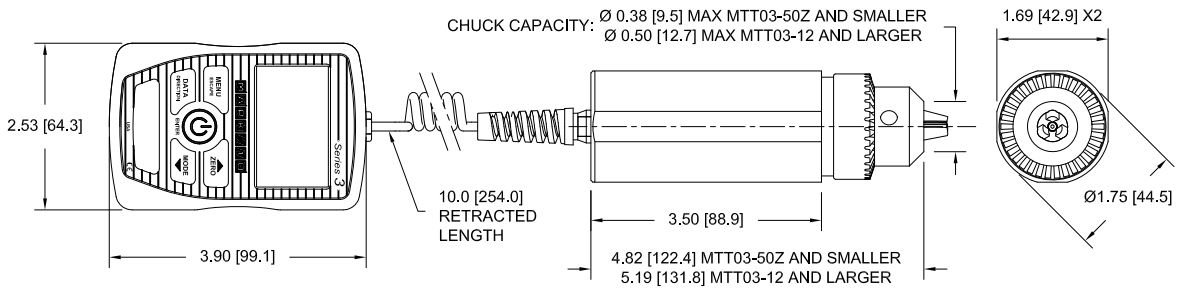

Series TT05

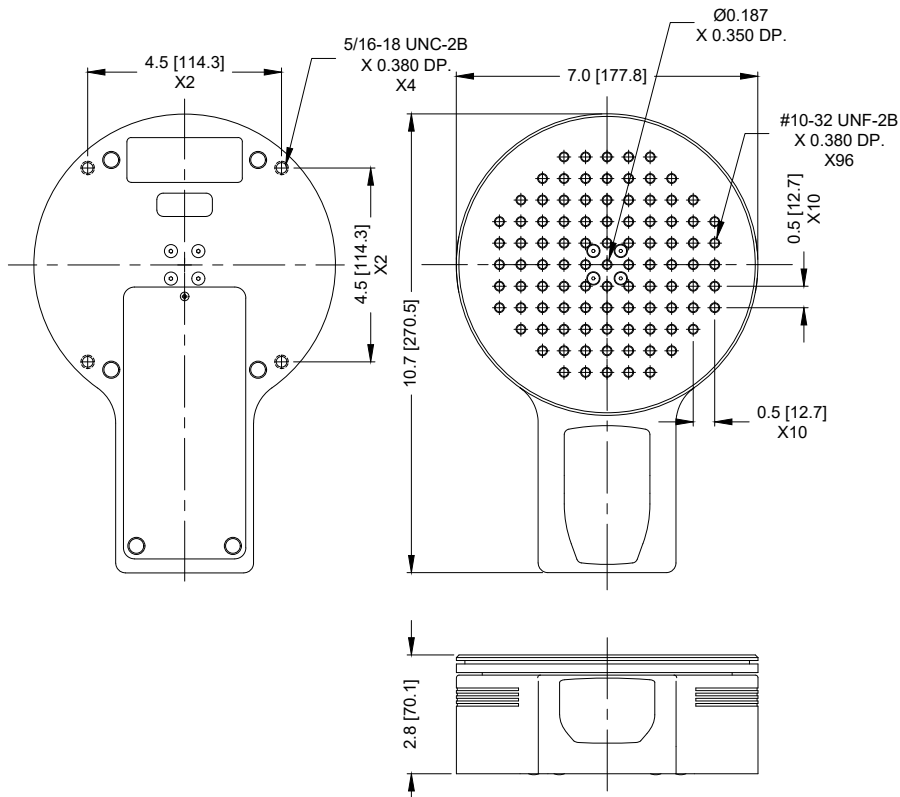



Plug & Test® Indicators & Sensors

Indicators

Model M7I

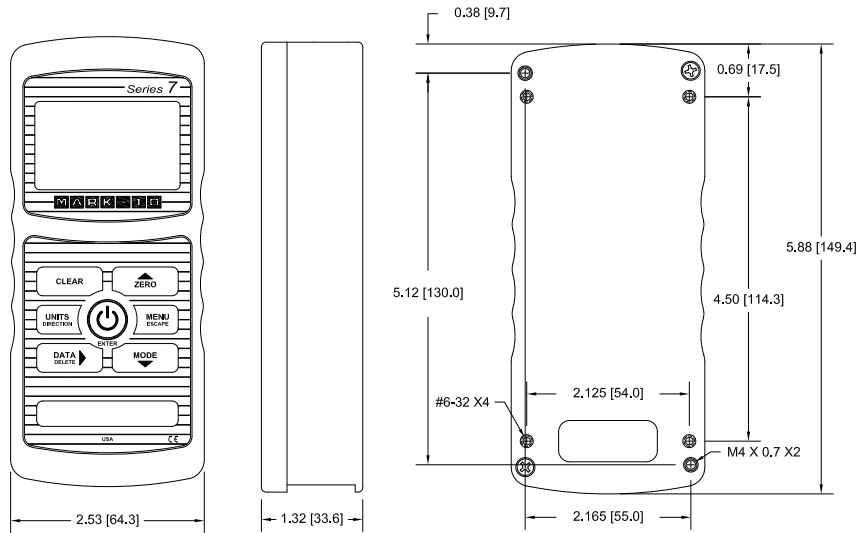

Model M5I

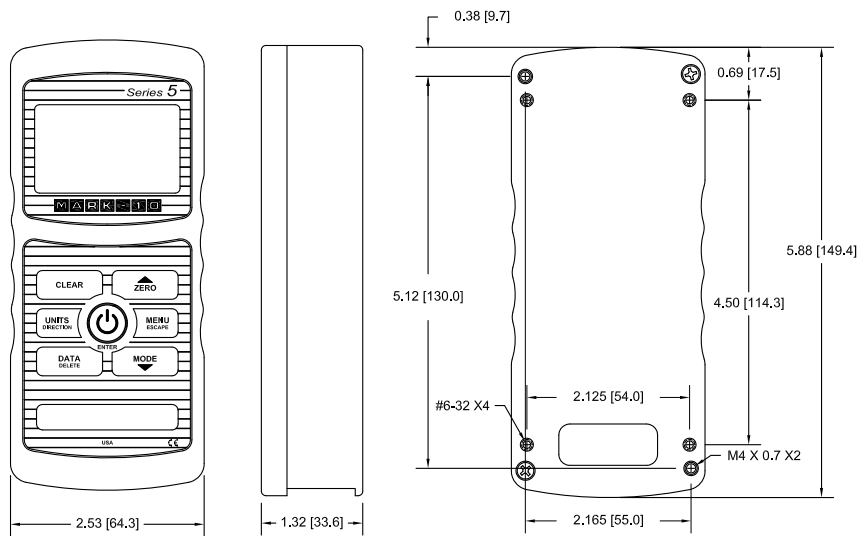

Model M3I

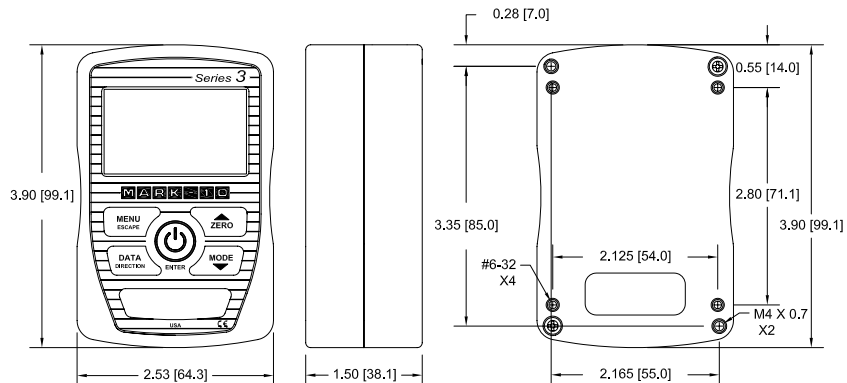



Force Sensors

Series R01

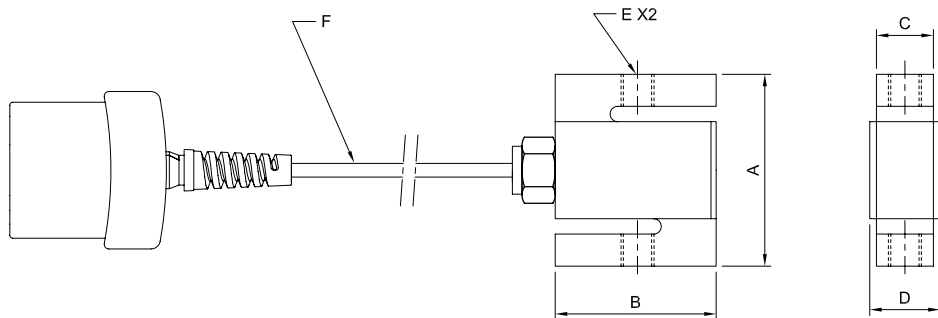

Model No.	A	B	C	D	E	F
MR01-50	2.40 [61.0]	2.00 [50.8]	0.46 [11.7]	0.90 [22.9]	1/4-28 UNF	MR01-XXXX: 20 ft [6 m] MR01-XXXX-1* 10 in [254 mm]*
MR01-100						
MR01-200						
MR01-300						
MR01-500	3.90 [99.1]	3.00 [76.2]	0.71 [18.0]	1.10 [27.9]	1/2-20 UNF	
MR01-750						
MR01-1000						
MR01-2000						
MR01-5000	3.90 [99.1]	3.00 [76.2]	0.96 [24.4]	1.40 [35.6]	3/4-16 UNF	
MR01-10000			1.21 [30.7]	1.63 [41.4]		

* Add suffix "-1" for shortened cable, for use on ESM1500, ESM750, ESM303, and ESM303H test stands. Ex: MR01-1000-1. Test stand mounting hardware is included.

Series R02

MR02-100 - MR02-2000:

MR02-5000 - MR02-10000:

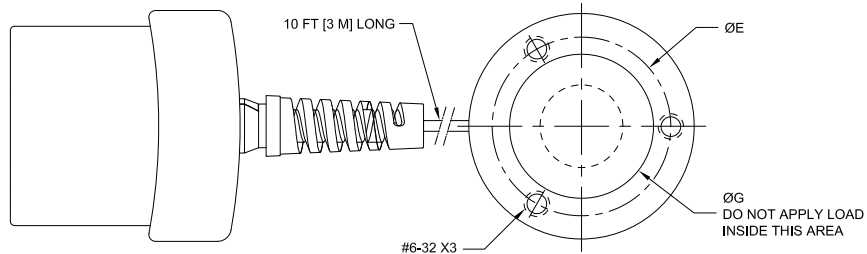
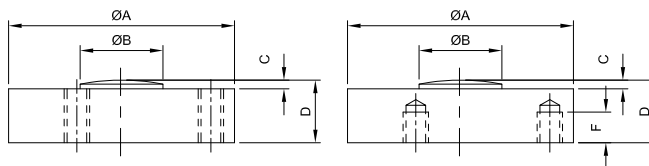

Model No.	ØA	ØB	C	D	ØE	F	ØG
MR02-100 - MR02-2000	1.23 [31.3]	0.32 [8.1]	0.05 [1.3]	0.39 [9.9]	1.0 [25.4]	THRU	0.83 [21.1]
MR02-5000 - MR02-10000	1.48 [37.6]	0.43 [10.9]	0.07 [1.8]	0.62 [15.8]	1.25 [31.8]	0.25 [6.4]	1.08 [27.4]



Series R03

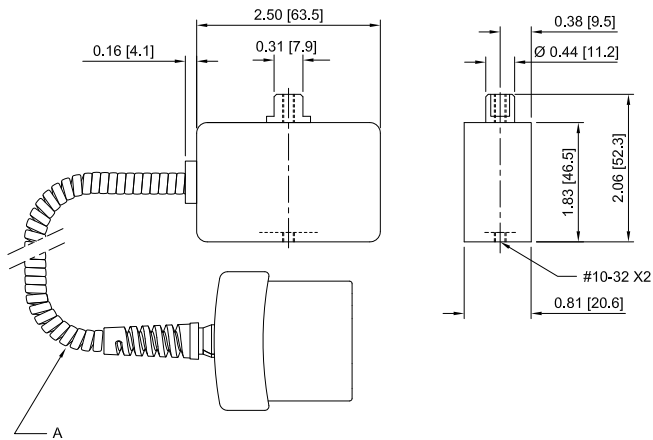

Model No.	A
MR03-XXX	24 in [609 mm] retracted, 10 ft [3 m] stretched
MR03-XXX-1*	10 in [254 mm], straight*

* Add suffix "-1" for shortened cable, for use on ESM1500, ESM750, ESM303, and ESM303H test stands. Ex: MR03-100-1. Test stand mounting hardware is included.

Series R05

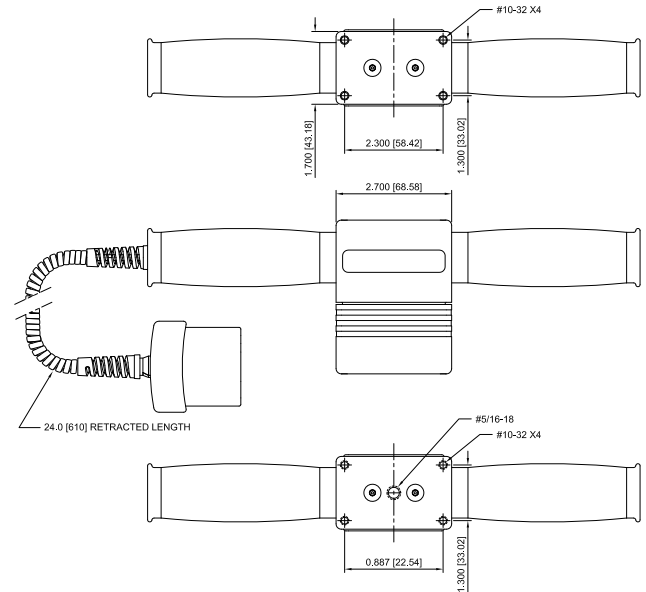

Series R04

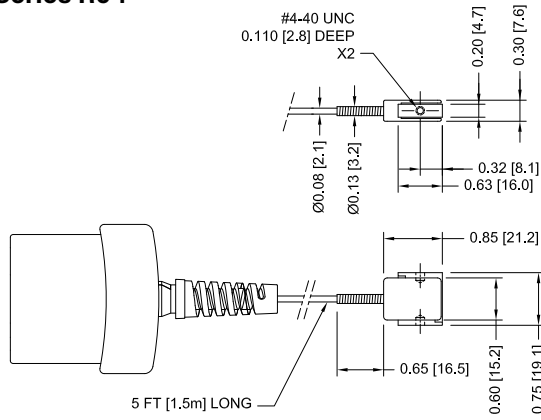

Series R06

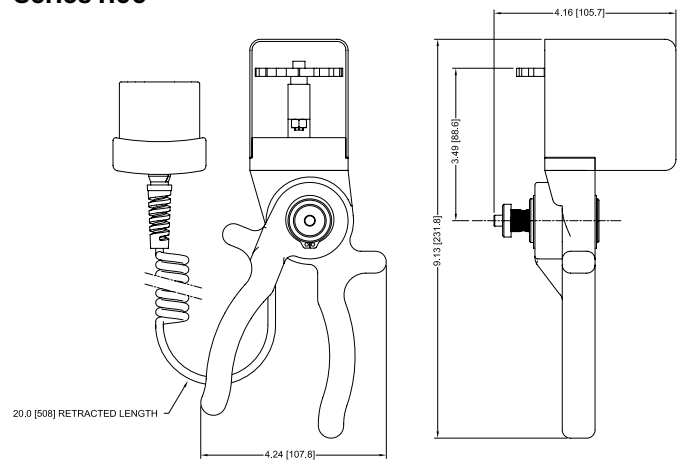



Series F Force Sensors

Series FS05 Force Sensors

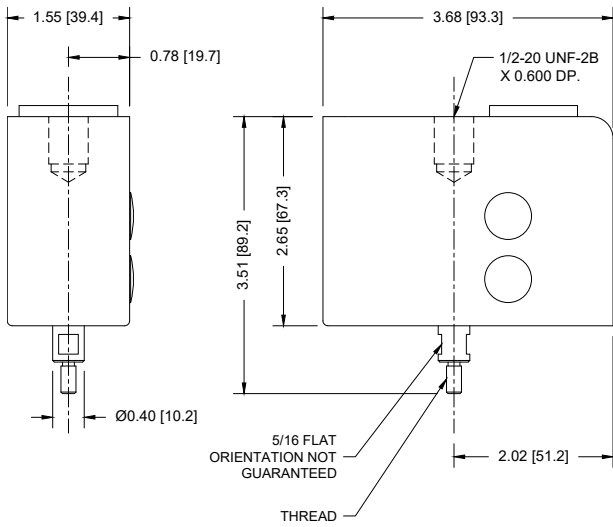

Model No.	Thread
FS05-012 - FS05-100	#10-32 UNF
FS05-200 - FS05-500	5/16-18 UNC

Series FS06 Force Sensors

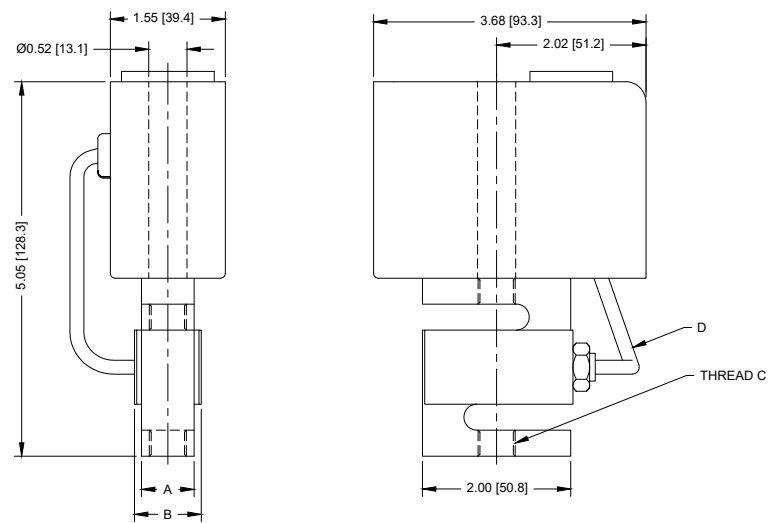

Model No.	A	B	C	D
FS05-012 - FS05-100	0.46 [11.7]	0.71 [18.0]	1/4-28 UNF	6.00 [152.4]
FS05-200 - FS05-500	0.90 [22.6]	1.10 [27.9]	1/2-20 UNF	

Series R07 Force Sensors

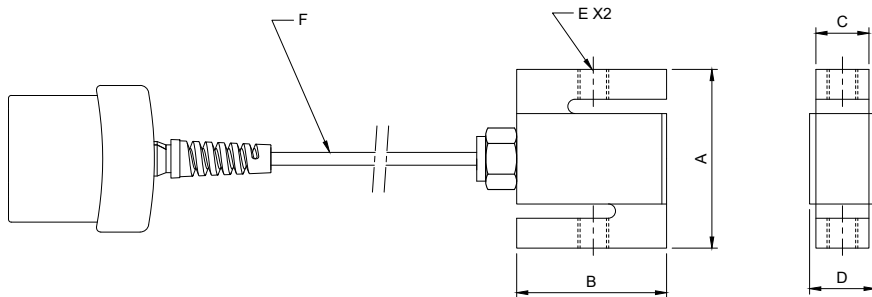

Model No.	A	B	C	D	E	F
MR07-50	2.40 [61.0]	2.00 [50.8]	0.46 [11.7]	0.90 [22.9]	1/4-28 UNF	10.00 [254.0]
MR07-100			0.71 [18.0]	1.10 [27.9]	1/2-20 UNF	
MR07-200			0.96 [24.4]	1.40 [35.6]		
MR07-300						
MR07-500						
MR07-750						
MR07-1000						
MR07-1500						



Torque Sensors

Series R50

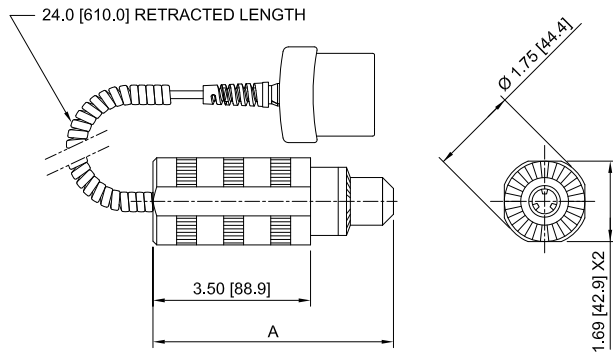

Model No.	A	Chuck Capacity
MR50-10Z - MR50-50Z	4.82 [122.4]	0.375 [9.5]
MR50-12 - MR50-100	5.19 [131.8]	0.5 [12.7]

Series R51

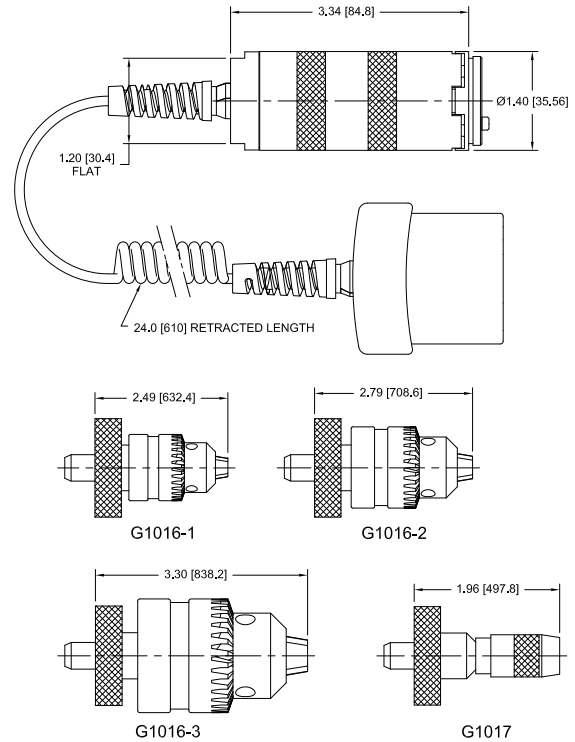

Series R52

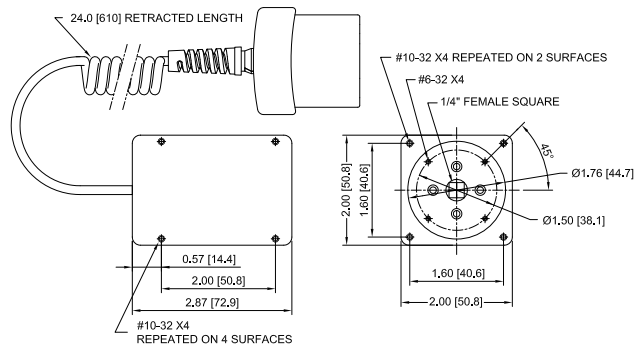

Series R55

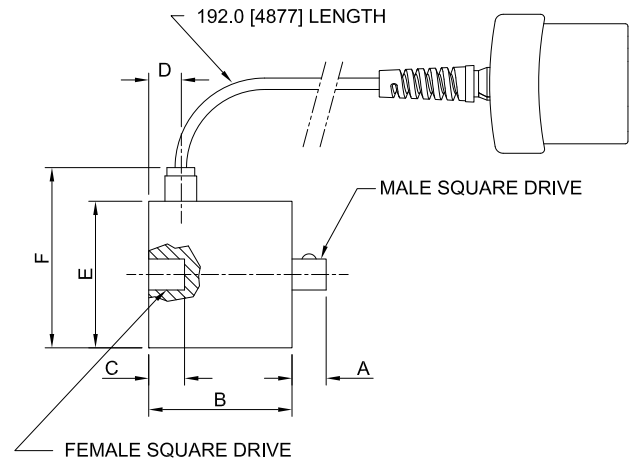

Model No.	Drive Size	A	B	C	D	ϕE	F
MR55-20 - MR55-100	1/4"	0.30 [7.5]	1.73 [44.0]	0.32 [8.0]			
MR55-200 - MR55-400	3/8"	0.41 [10.5]	1.73 [44.0]	0.43 [11.0]	0.39 [10.0]	1.77 [45.0]	2.32 [59.0]
MR55-1000	1/2"	0.59 [15.0]		0.63 [16.0]			
MR55-5000	3/4"	0.89 [22.5]	2.11 [53.5]	0.94 [24.0]	0.77 [19.5]	2.01 [51.0]	2.56 [65.0]



Wire Crimp Pull Testers

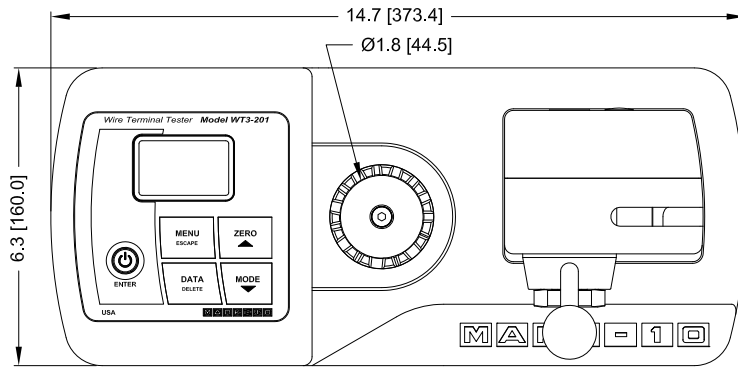

Model WT3-201

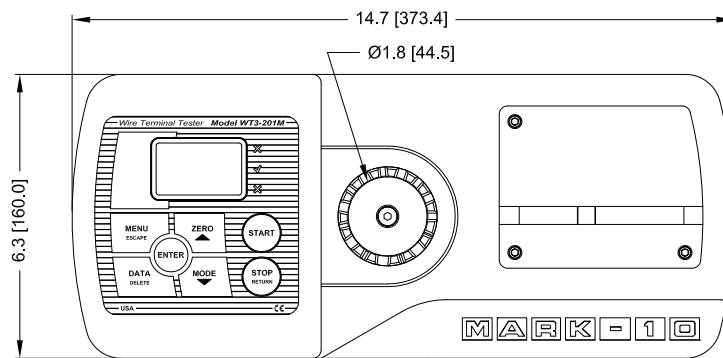
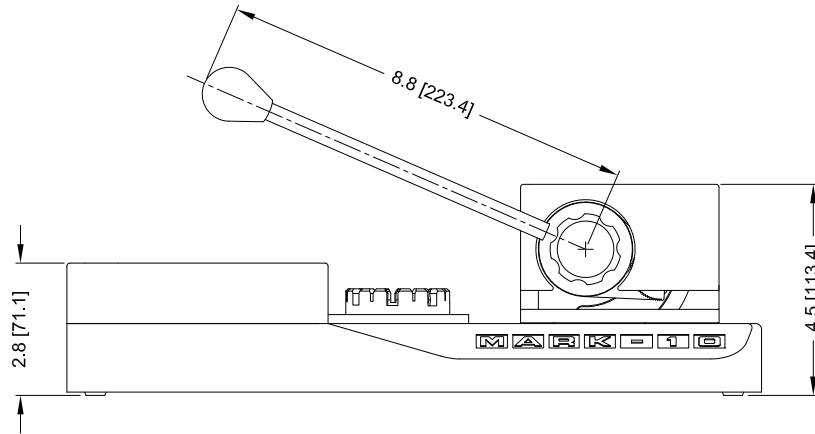

Model WT3-201M

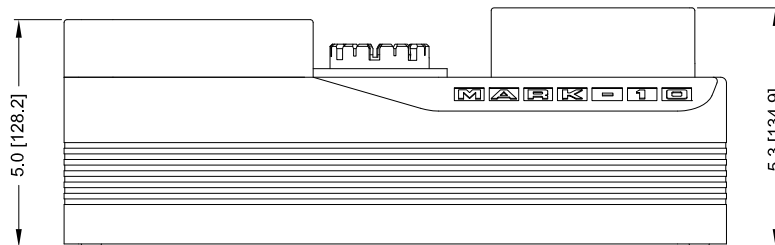



Manual Test Stands

Model ES05

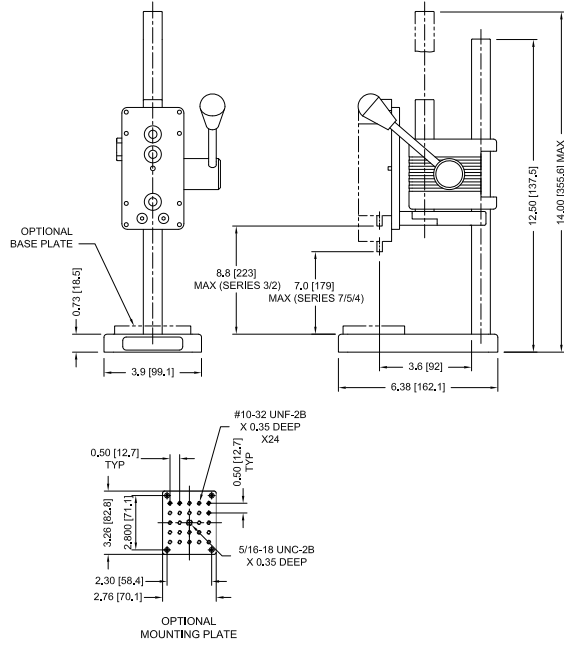

Model ES10

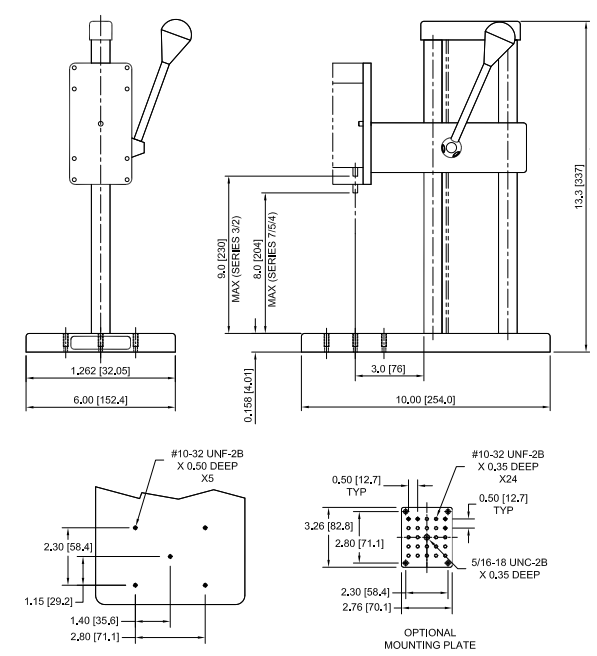

Model ES20

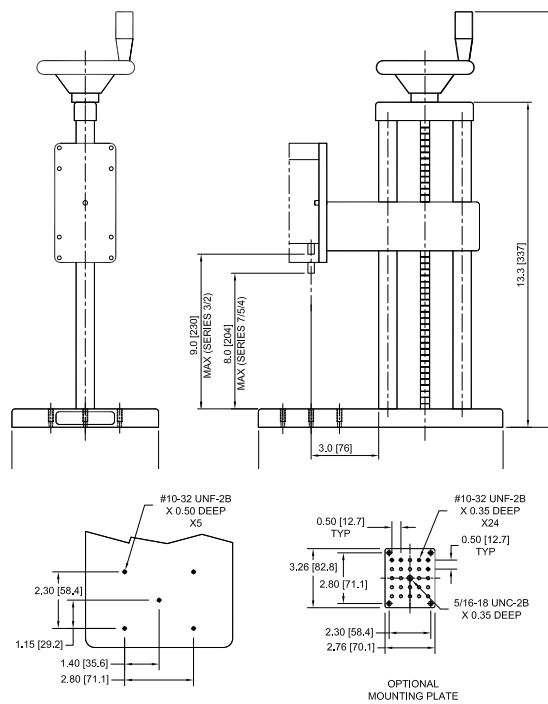

Model ES30

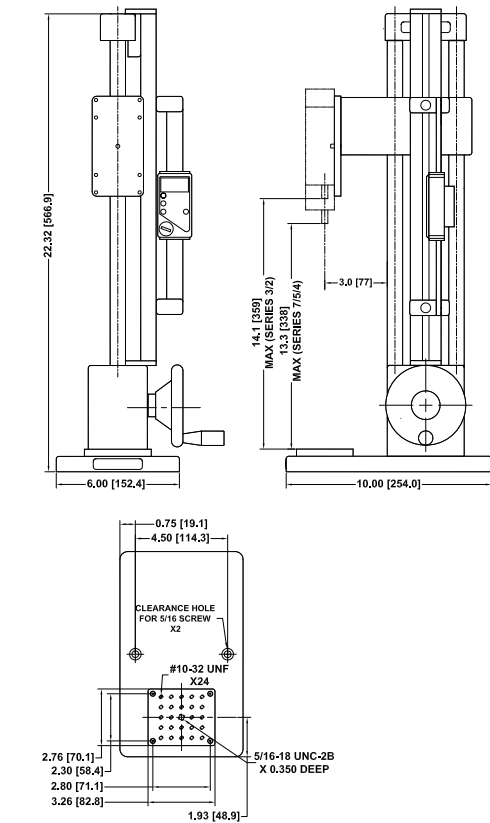



Dimensional Drawings ▶ Manual Test Stands

Model TSA750

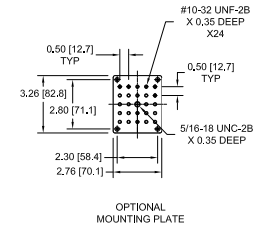
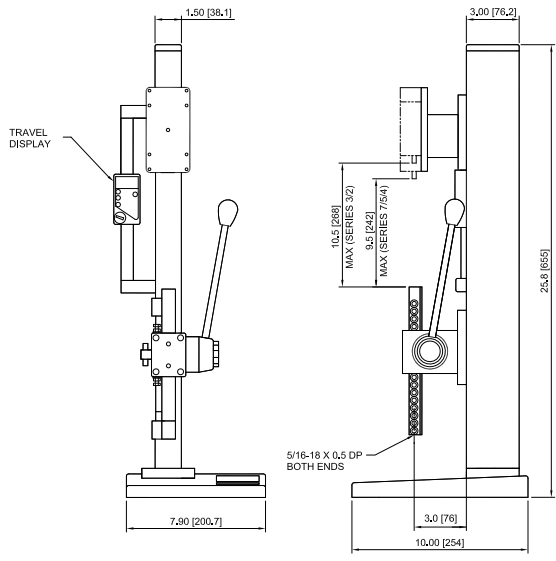

Model TSA750H

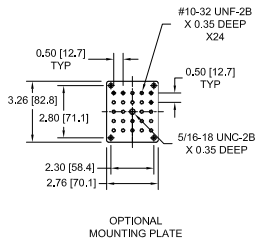
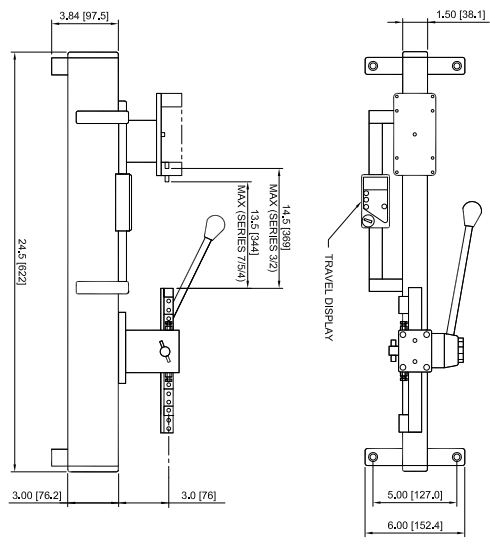

Model TSB100

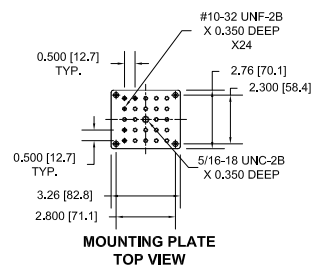
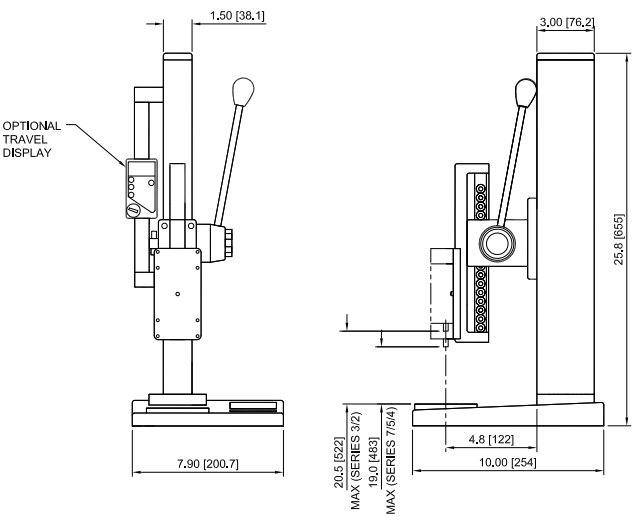

Model TSC1000

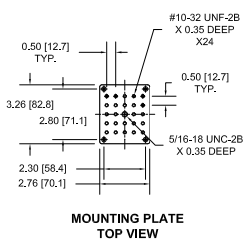
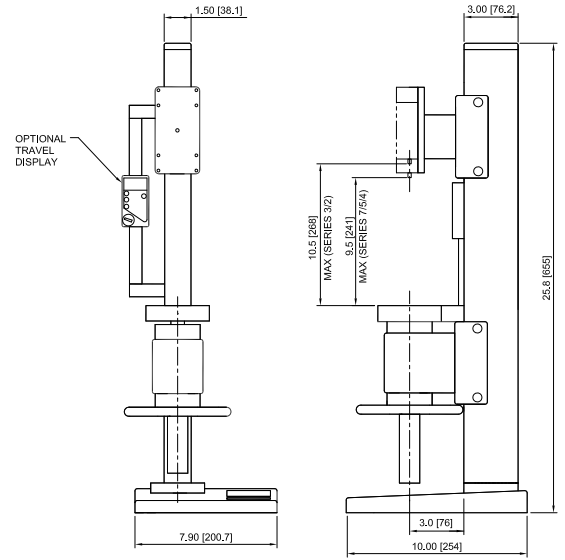



Model TSC1000H

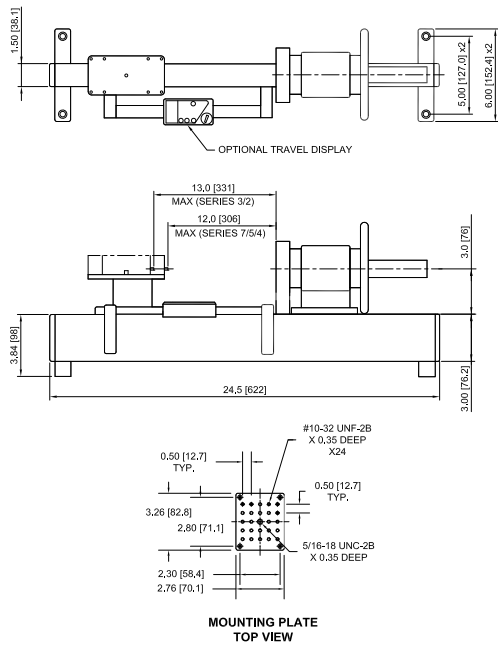

Model TSF

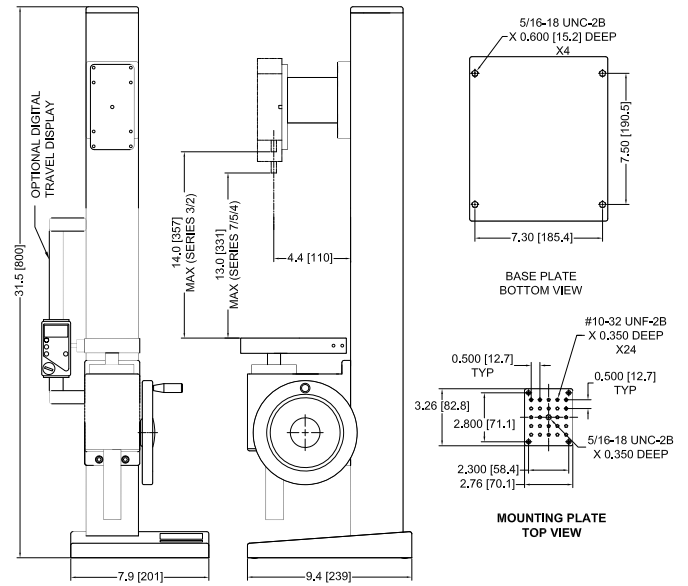

Model TSFH

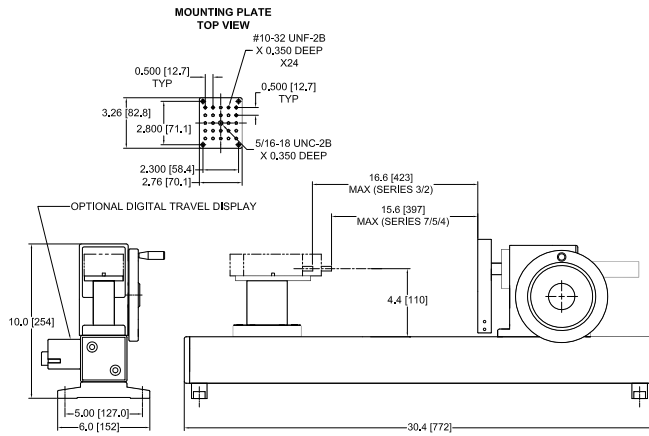

Motorized Force Testers

F105 / F305 / F505

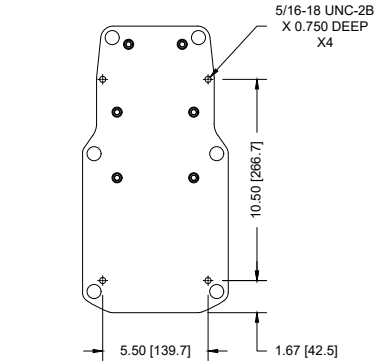
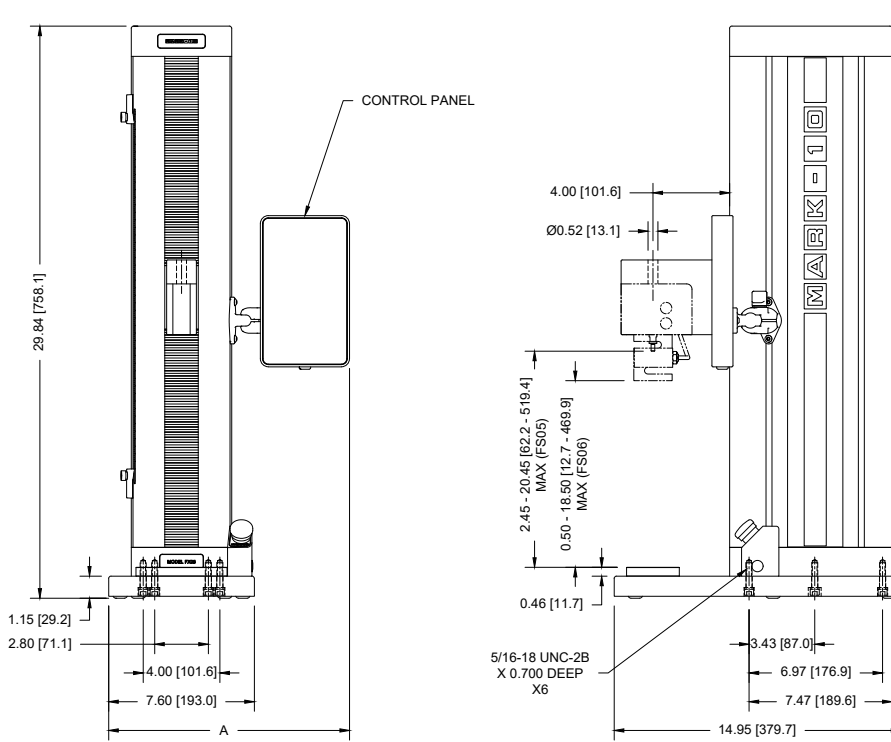

BENCH MOUNTING HOLES
BOTTOM VIEW

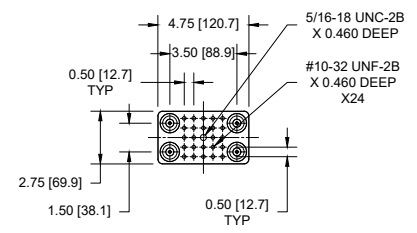

MOUNTING PLATE
TOP VIEW

Control Panel	A
EasyMESUR®	12.57 [319.2]
IntelliMESUR®	17.30 [439.3]

F505H

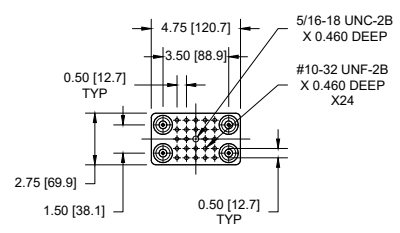
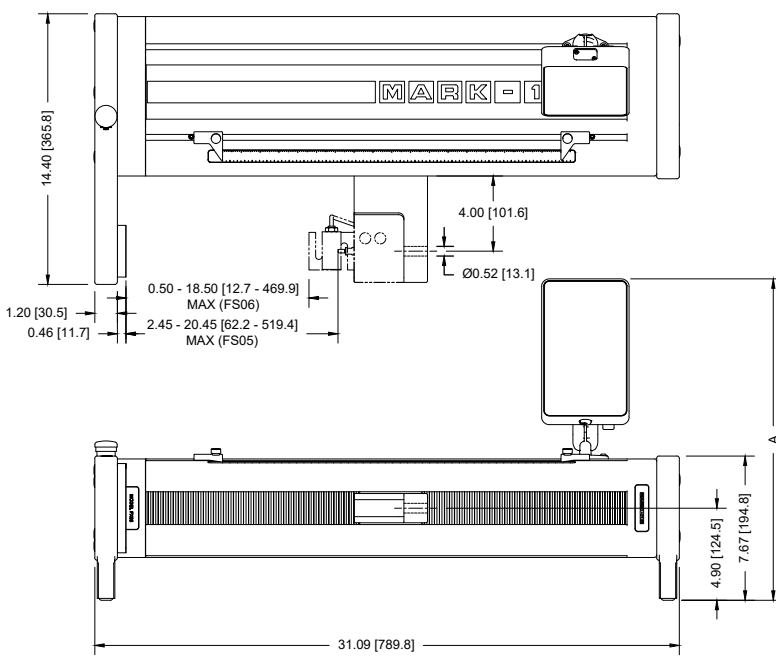

MOUNTING PLATE
TOP VIEW

Control Panel	A
EasyMESUR®	1710 [434.2]
IntelliMESUR®	16.23 [412.2]



F755 / F755S / F1505 / F1505S

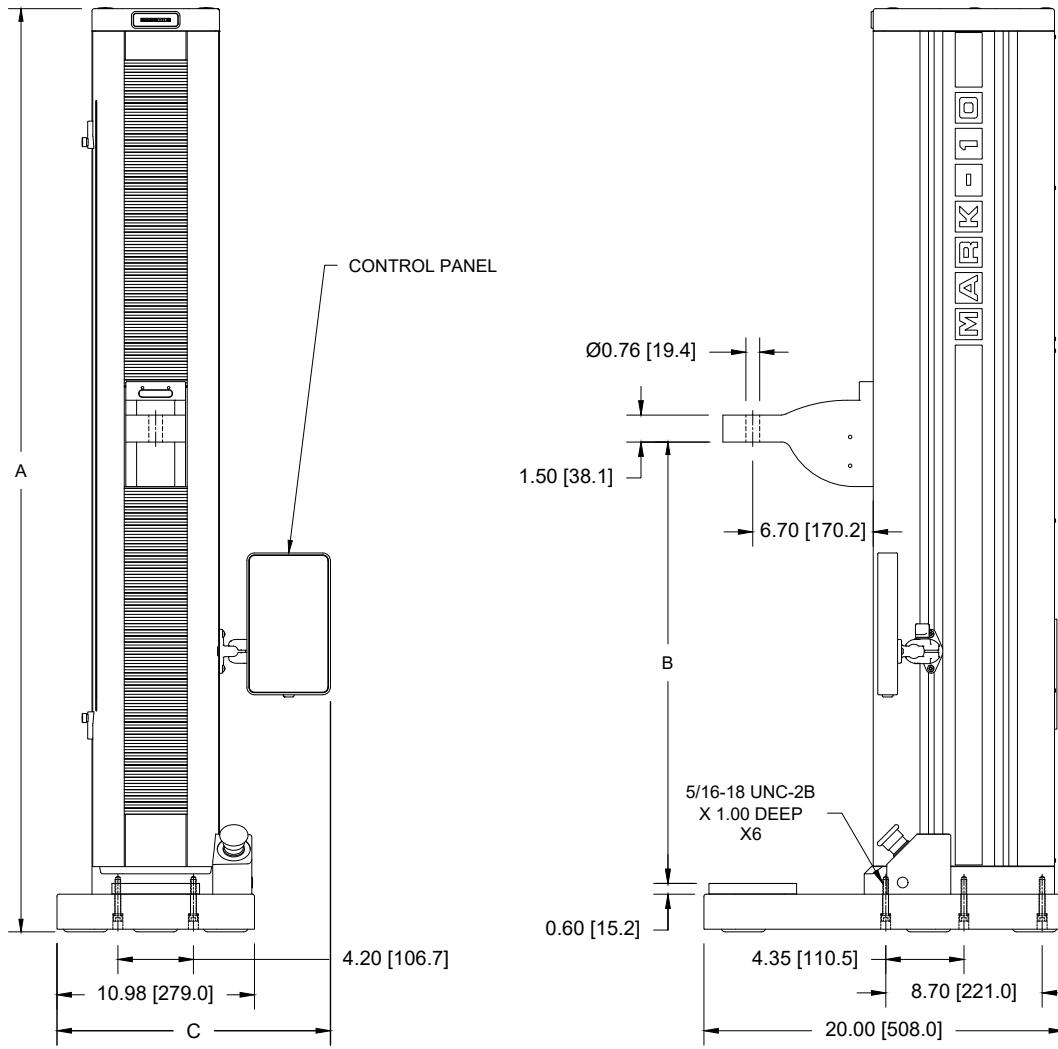

Model	A	B
F1505	51.35 [1304.3]	8.125 - 40.125 [206.4 - 1019.2]
F755	51.35 [1304.3]	8.125 - 40.125 [206.4 - 1019.2]
F1505S	33.89 [860.9]	8.125 - 22.33 [206.4 - 567.1]
F755S	33.89 [860.9]	8.125 - 22.33 [206.4 - 567.1]

Control Panel	C
EasyMESUR®	15.22 [386.5]
IntelliMESUR®	19.95 [506.7]

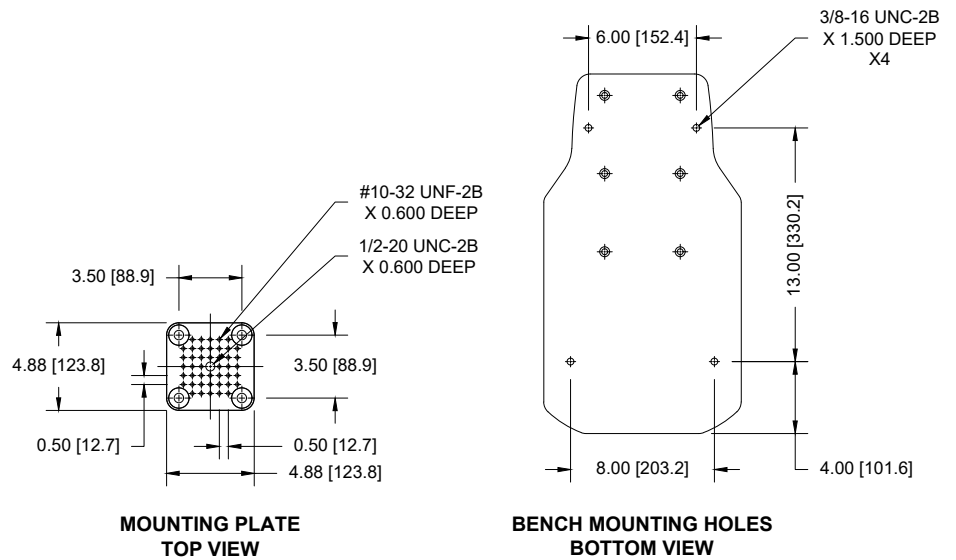



Torque Testers

Model TST

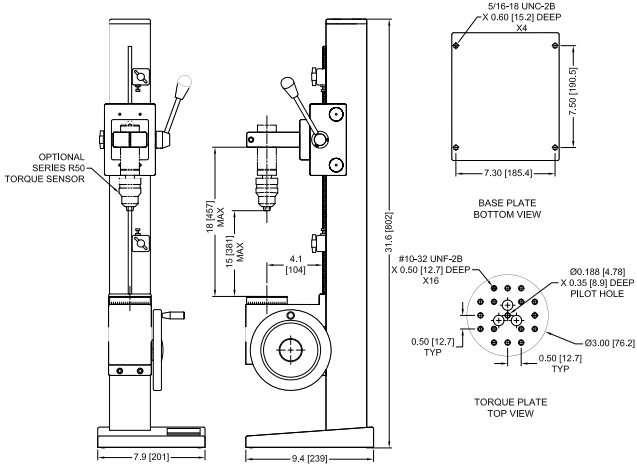

Model TSTH

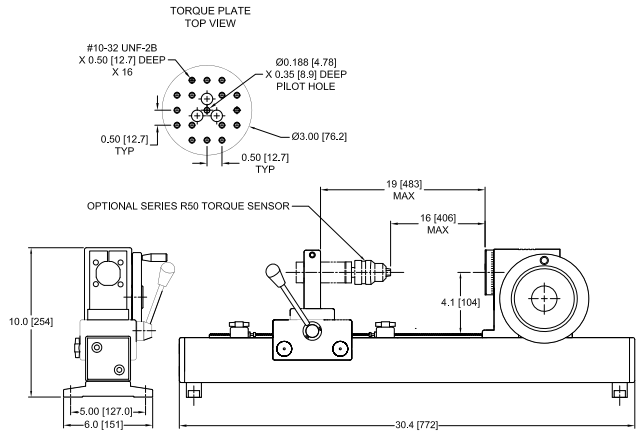

Model TSTM-DC

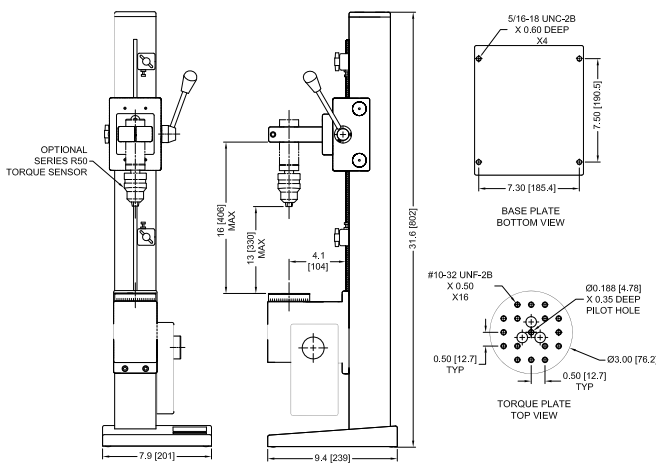

Model TSTMH-DC

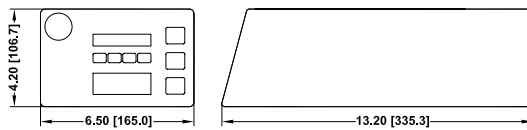
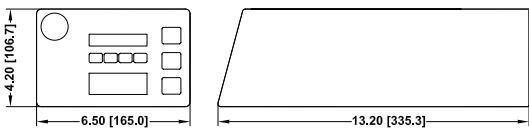
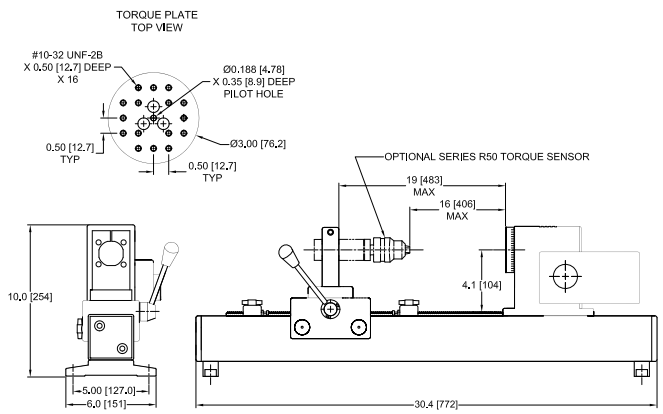





Applications are virtually limitless...

Mark-10 force and torque measurement products help quality control, engineering, and manufacturing professionals assess and ensure quality in virtually every industry worldwide.



Automotive



Aerospace



Electronics



Consumer Products



Springs



Medical Device



Packaging



Food & Beverage



Ergonomics

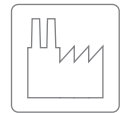

Other Industries

MARK-10

Force & Torque Measurement Engineered Better

Mark-10 Corporation

11 Dixon Avenue ■ Copiague, NY 11726 USA

888-MARK-TEN ■ Tel: +1 631 842 9200 ■ Fax: +1 631 842 9201

www.mark-10.com ■ info@mark-10.com



© 2023 MARK-10 CORPORATION
32-1000